

PNP Silicon RF Transistor

BF 660

- For VHF oscillator applications

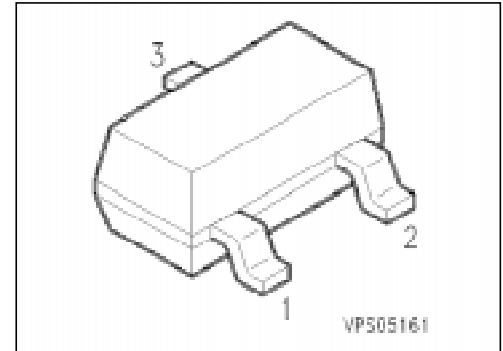

Type	Marking	Ordering Code (tape and reel)	Pin Configuration			Package ¹⁾
			1	2	3	
BF 660	LEs	Q62702-F982	B	E	C	SOT-23

Maximum Ratings

Parameter	Symbol	Values	Unit
Collector-emitter voltage	V_{CE0}	30	V
Collector-base voltage	V_{CB0}	40	
Emitter-base voltage	V_{EB0}	4	
Collector current	I_C	25	mA
Emitter current	I_E	30	
Total power dissipation, $T_A \leq 25 \text{ }^\circ\text{C}$	P_{tot}	280	mW
Junction temperature	T_j	150	$^\circ\text{C}$
Storage temperature range	T_{stg}	- 65 ... + 150	

Thermal Resistance

Junction - ambient ²⁾	$R_{th \text{ JA}}$	≤ 450	K/W
----------------------------------	---------------------	------------	-----

¹⁾ For detailed information see chapter Package Outlines.

²⁾ Package mounted on alumina 15 mm × 16.7 mm × 0.7 mm.

Electrical Characteristics

at $T_A = 25\text{ °C}$, unless otherwise specified.

Parameter	Symbol	Values			Unit
		min.	typ.	max.	

DC Characteristics

Collector-emitter breakdown voltage $I_C = 1\text{ mA}, I_B = 0$	$V_{(BR) CE0}$	30	–	–	V
Collector-base breakdown voltage $I_C = 10\text{ }\mu\text{A}, I_E = 0$	$V_{(BR) CB0}$	40	–	–	
Emitter-base breakdown voltage $I_E = 10\text{ }\mu\text{A}, I_C = 0$	$V_{(BR) EB0}$	4	–	–	
Collector cutoff current $V_{CB} = 20\text{ V}, I_E = 0$	I_{CB0}	–	–	50	nA
DC current gain $I_C = 3\text{ mA}, V_{CE} = 10\text{ V}$	h_{FE}	30	–	–	–

AC Characteristics

Transition frequency $I_C = 5\text{ mA}, V_{CE} = 10\text{ V}, f = 100\text{ MHz}$	f_t	–	700	–	MHz
Collector-base capacitance $V_{CB} = 10\text{ V}, V_{BE} = 0\text{ V}, f = 1\text{ MHz}$	C_{cb}	–	0.6	–	pF
Collector-emitter capacitance $V_{CE} = 10\text{ V}, V_{BE} = 0\text{ V}, f = 1\text{ MHz}$	C_{ce}	–	0.28	–	

Total power dissipation $P_{tot} = f(T_A)$

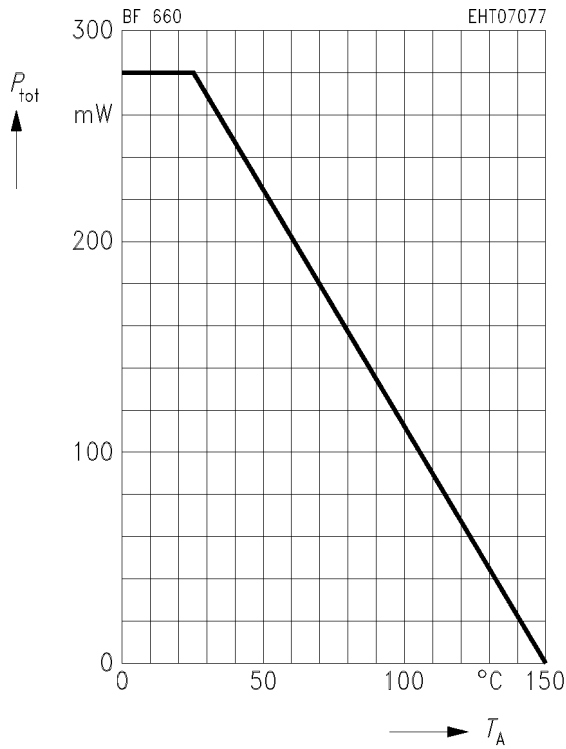

Transition frequency $f_T = f(I_C)$

$V_{CE} = 10\text{ V}, f = 100\text{ MHz}$

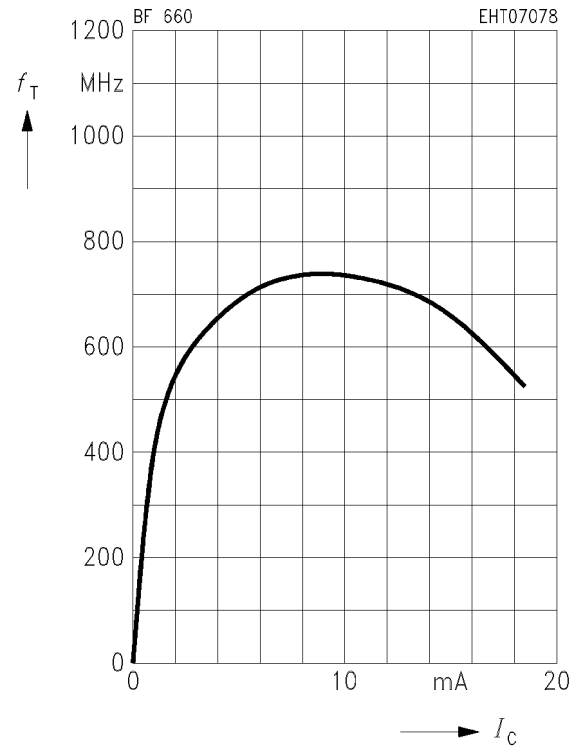

Collector-base capacitance $C_{cb} = f(V_{CB})$

$f = 1\text{ MHz}$

