

Low Vcesat NPN Epitaxial Planar Transistor

BTD2040N3S

BV_{CEO}	25V
I_C	1A
R_{CESAT}	0.31 Ω (typ.)

Features

- The BTD2040N3S is designed for general purpose low frequency power amplifier applications.
- Low $V_{CE(sat)}$, $V_{CE(sat)}=40mV$ (typical), at $I_C / I_B = 50mA / 2.5mA$
- Pb-free lead plating and halogen-free package

Symbol

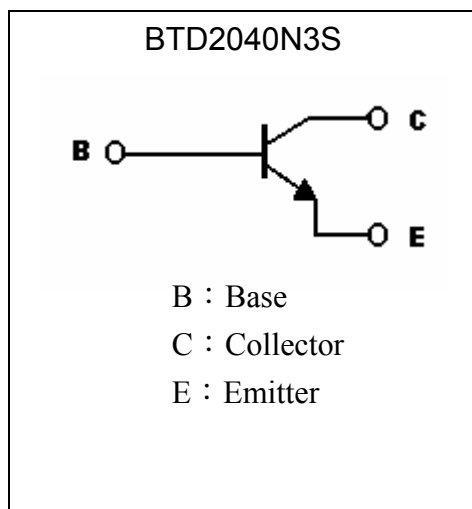

Outline

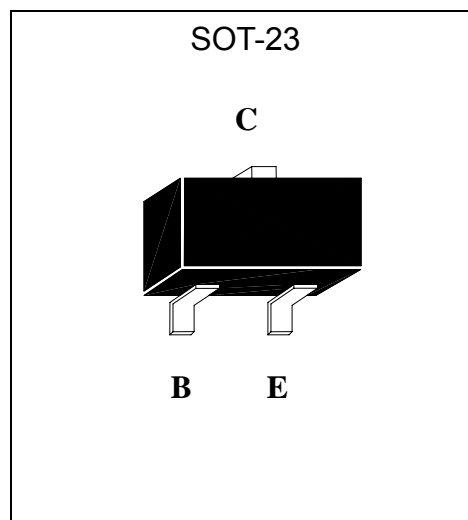

Absolute Maximum Ratings (Ta=25°C)

Parameter	Symbol	Limits	Unit
Collector-Base Voltage	V_{CBO}	45	V
Collector-Emitter Voltage	V_{CEO}	25	V
Emitter-Base Voltage	V_{EBO}	6	V
Collector Current (DC)	I_C	1	A
Collector Current (Pulse)	I_{CP}	2 (Note)	A
Power Dissipation	P_D	225	mW
Junction Temperature	T_j	150	°C
Storage Temperature	T_{stg}	-55~+150	°C

Note : Single pulse, Pw=10ms

**Characteristics (Ta=25°C)**

Symbol	Min.	Typ.	Max.	Unit	Test Conditions
BV _{CBO}	45	-	-	V	I _C =100μA, I _E =0
BV _{CEO}	25	-	-	V	I _C =2mA, I _B =0
BV _{EBO}	6	-	-	V	I _E =100μA, I _C =0
I _{CBO}	-	-	0.5	μA	V _{CB} =30V, I _E =0
I _{EBO}	-	-	0.5	μA	V _{EB} =6V, I _C =0
*V _{CE(sat)1}	-	40	60	mV	I _C =50mA, I _B =2.5mA
*V _{CE(sat)2}	-	0.15	0.3	V	I _C =400mA, I _B =20mA
*V _{CE(sat)3}	-	0.25	0.5	V	I _C =800mA, I _B =80mA
*R _{CE(sat)}	-	0.31	0.62	Ω	I _C =800mA, I _B =80mA
*V _{BE(on)}	-	-	1	V	V _{CE} =1V, I _C =10mA
*h _{FE1}	150	-	450	-	V _{CE} =1V, I _C =100mA
*h _{FE2}	40	-	-	-	V _{CE} =1V, I _C =800mA
*h _{FE3}	82	-	-	-	V _{CE} =2V, I _C =50mA
f _T	100	-	-	MHz	V _{CE} =5V, I _C =50mA, f=100MHz
Cob	-	6	-	pF	V _{CB} =10V, f=1MHz

*Pulse Test : Pulse Width ≤380μs, Duty Cycles≤2%

Ordering Information

Device	Package	Shipping	Marking
BTD2040N3S	SOT-23 (Pb-free lead plating and halogen-free package)	3000 pcs / Tape & Reel	BS

Moisture Sensitivity Level : Conform to JEDEC Level 1

Recommended Storage Condition:

Temperature : ≤ 30 °C

Humidity : ≤ 60% RH

Typical Characteristics

Emitter Grounded Output Characteristics

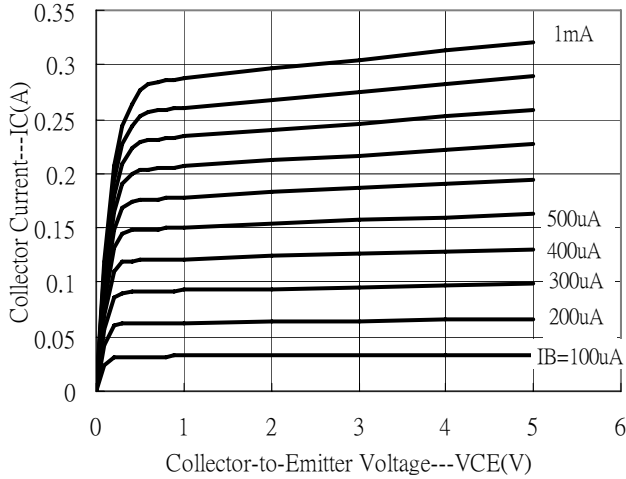

Emitter Grounded Output Characteristics

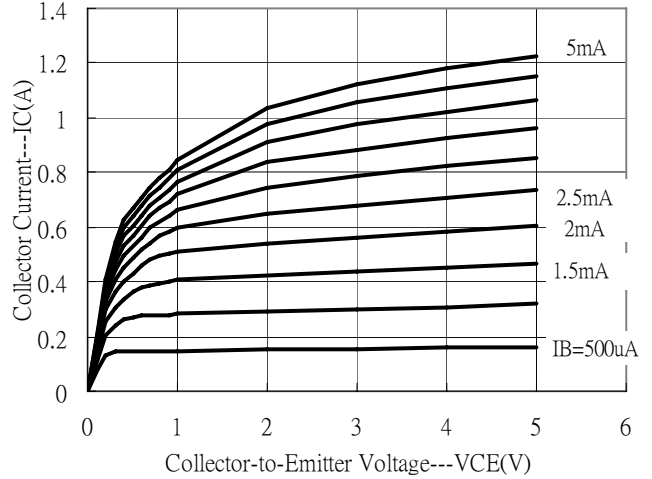

Current Gain vs Collector Current

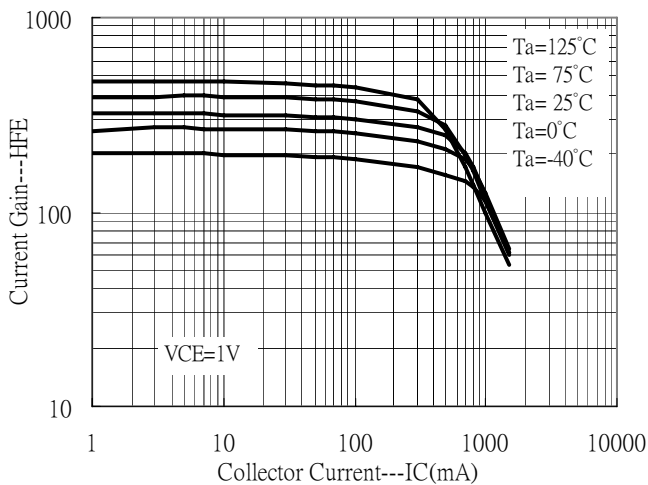

Current Gain vs Collector Current

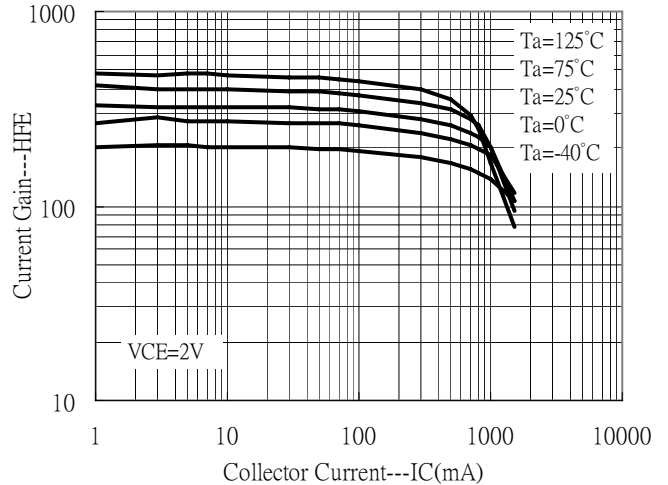

Current Gain vs Collector Current

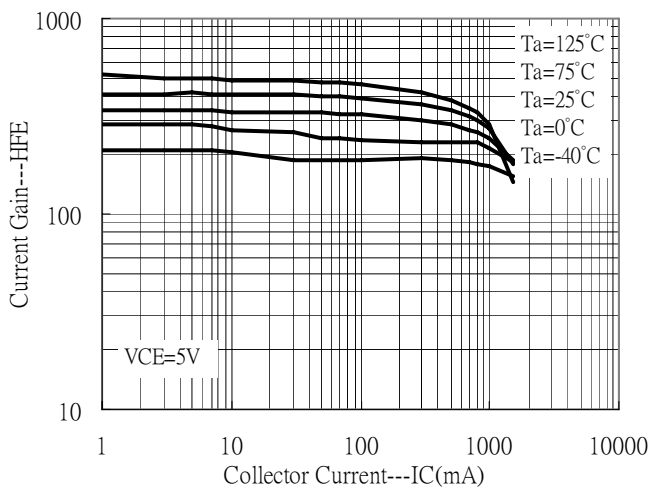

Saturation Voltage vs Collector Current

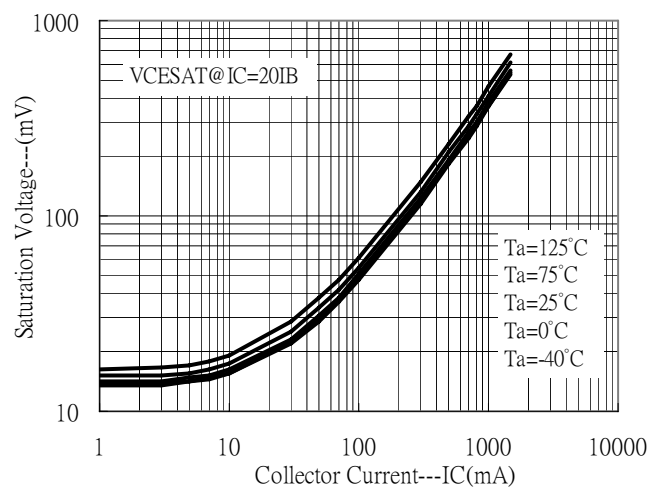



Typical Characteristics(Cont.)

Saturation Voltage vs Collector Current

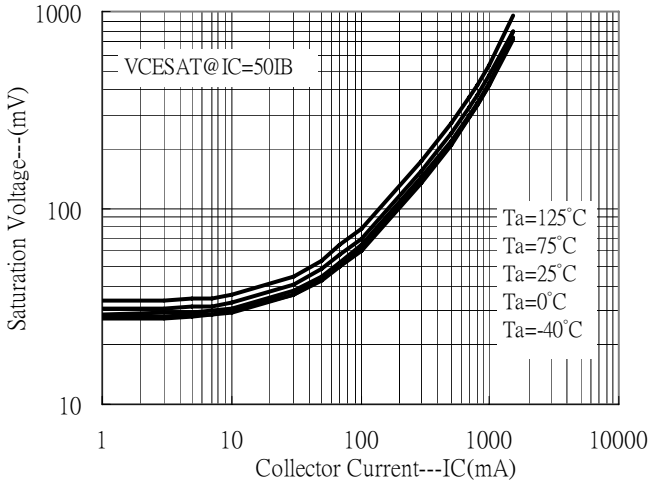

Saturation Voltage vs Collector Current

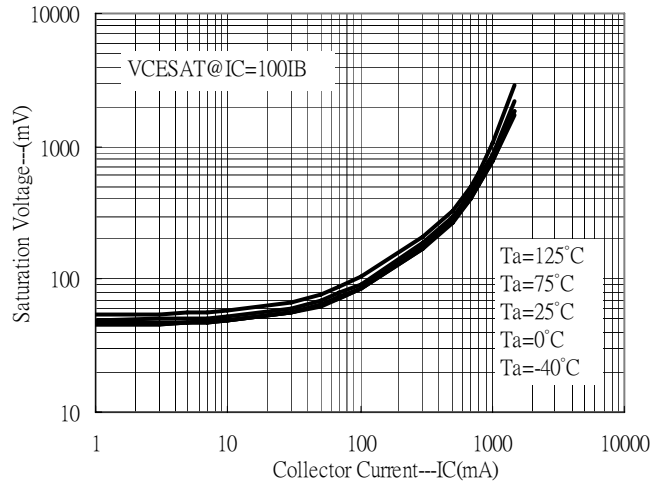

Saturation Voltage vs Collector Current

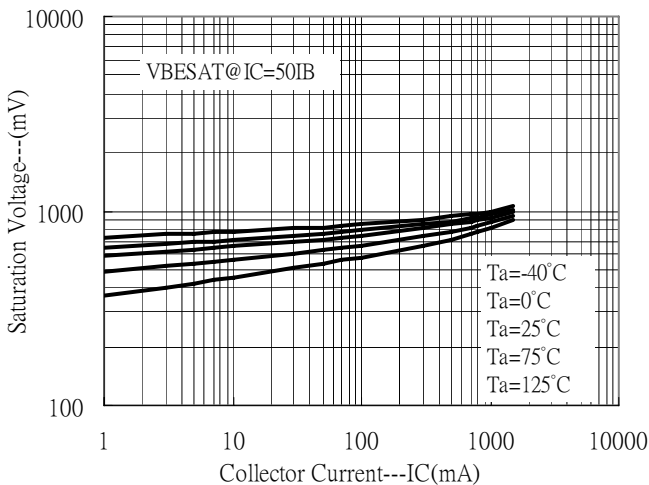

On Voltage vs Collector Current

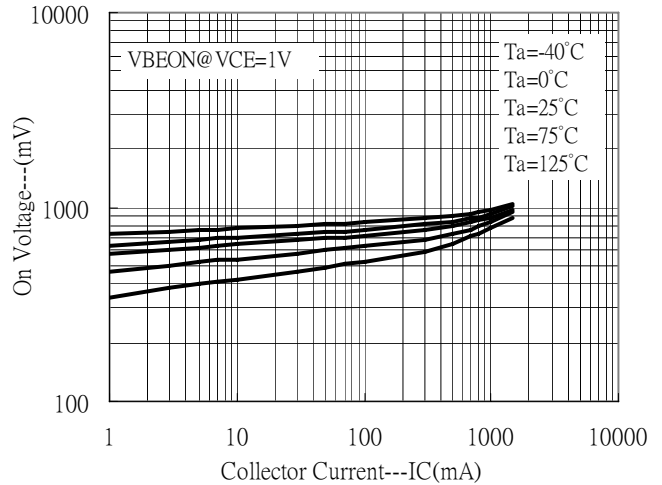

Capacitance vs Reverse-biased Voltage

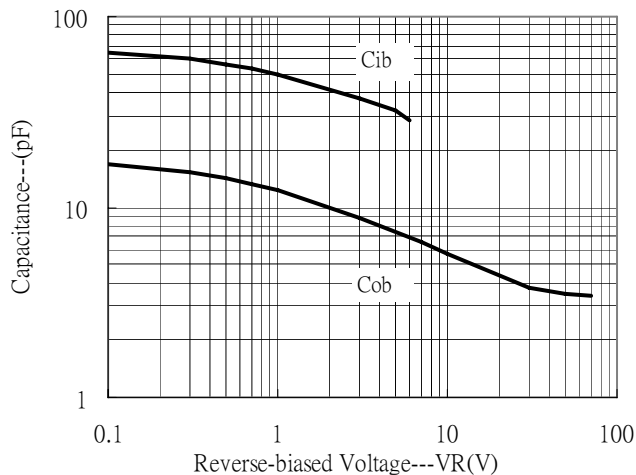

Cutoff Frequency vs Collector Current

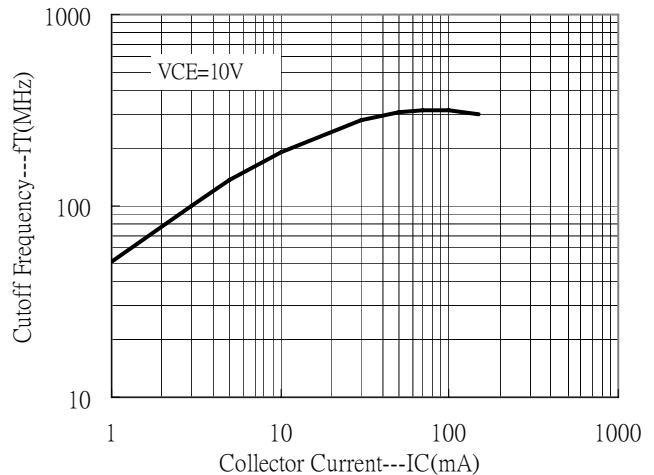



Typical Characteristics(Cont.)

Power Derating Curve

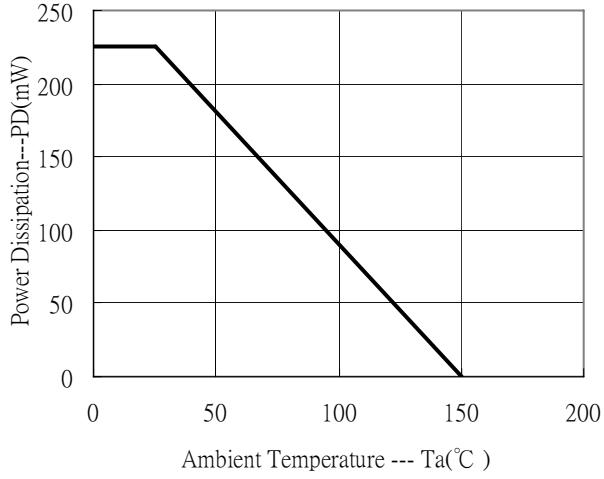

Reel Dimension

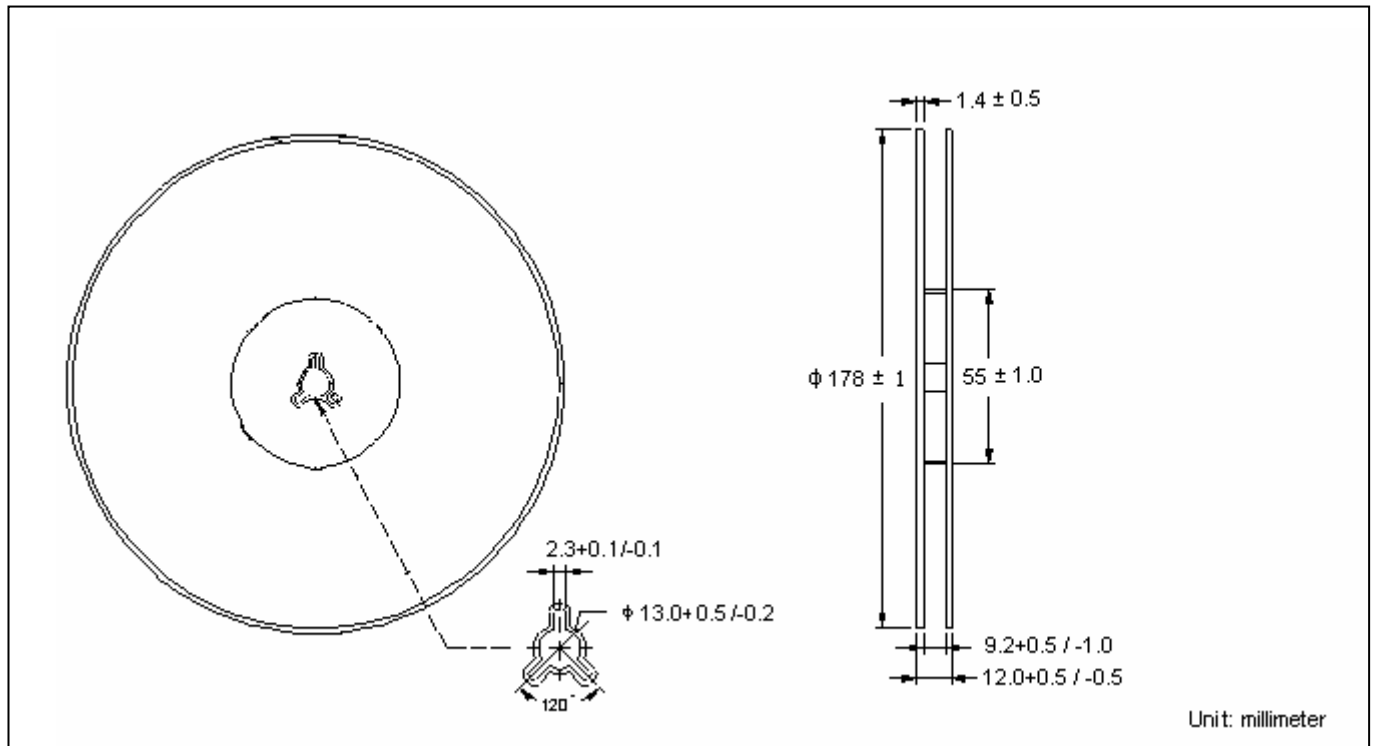

Carrier Tape Dimension

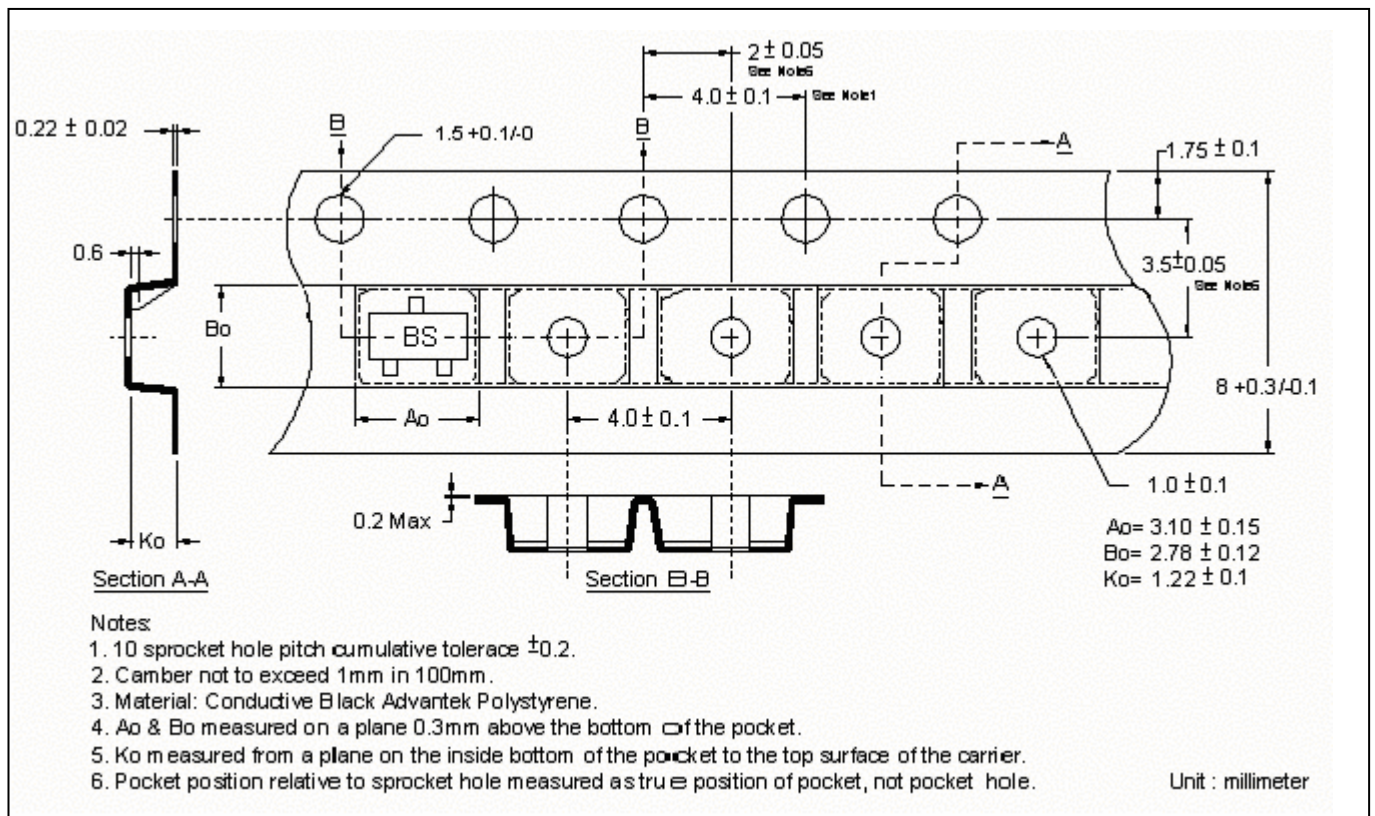

Recommended wave soldering condition

Product	Peak Temperature	Soldering Time
Pb-free devices	260 +0/-5 °C	5 +1/-1 seconds

Recommended temperature profile for IR reflow

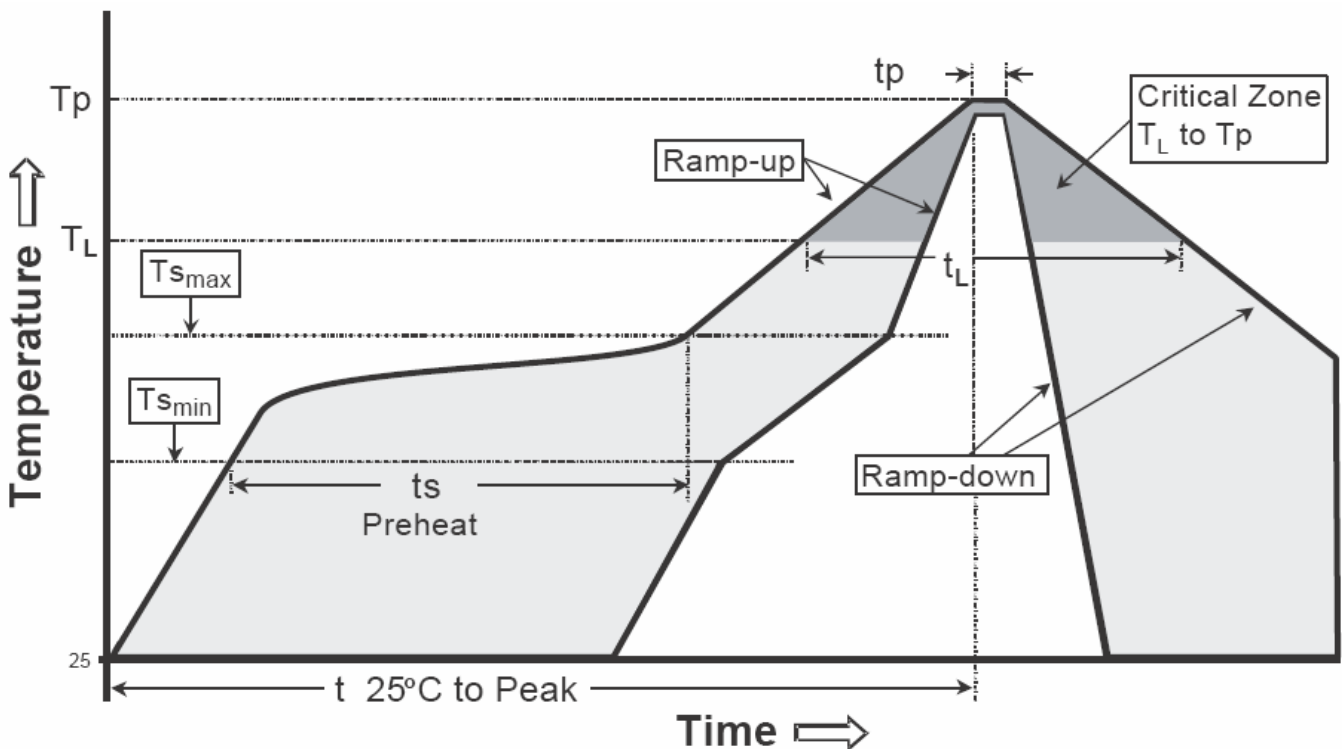

Profile feature	Sn-Pb eutectic Assembly	Pb-free Assembly
Average ramp-up rate (Ts_max to Tp)	3°C/second max.	3°C/second max.
Preheat		
-Temperature Min(Ts_min)	100°C	150°C
-Temperature Max(Ts_max)	150°C	200°C
-Time(ts_min to ts_max)	60-120 seconds	60-180 seconds
Time maintained above:		
-Temperature (T _L)	183°C	217°C
- Time (t _L)	60-150 seconds	60-150 seconds
Peak Temperature(T _P)	240 +0/-5 °C	260 +0/-5 °C
Time within 5°C of actual peak temperature(tp)	10-30 seconds	20-40 seconds
Ramp down rate	6°C/second max.	6°C/second max.
Time 25 °C to peak temperature	6 minutes max.	8 minutes max.

Note : All temperatures refer to topside of the package, measured on the package body surface.

SOT-23 Dimension

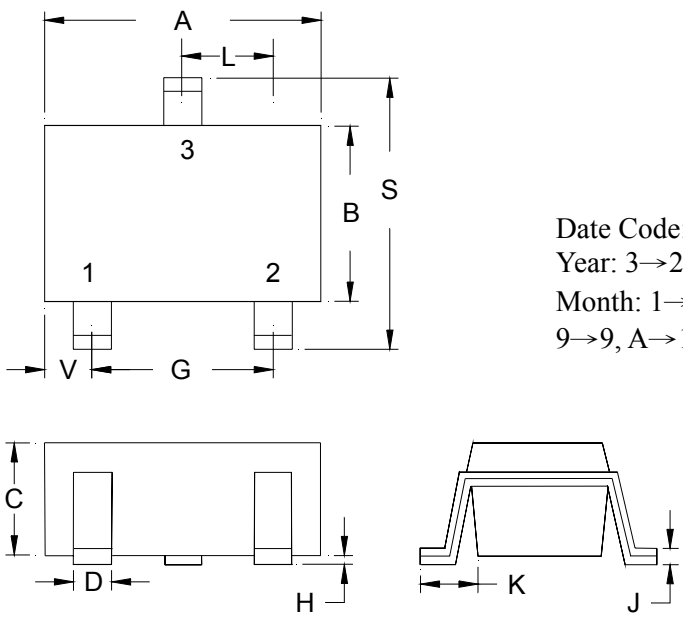

The diagram shows three views of the SOT-23 package: a top view with dimensions A, L, B, S, 1, 2, 3, V, and G; a side view with dimensions C, D, and H; and a perspective view with dimensions K and J.

Marking:

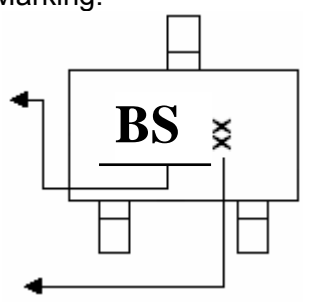

Product Code

Date Code: Year+Month
 Year: 3→2003, 4→2004
 Month: 1→1, 2→2, . . .
 9→9, A→10, B→11, C→12

3-Lead SOT-23 Plastic Surface Mounted Package
 CYStek Package Code: N3

Style : Pin 1.Base 2.Emitter 3.Collector

*:Typical

DIM	Inches		Millimeters		DIM	Inches		Millimeters	
	Min.	Max.	Min.	Max.		Min.	Max.	Min.	Max.
A	0.1102	0.1204	2.80	3.04	J	0.0034	0.0070	0.085	0.177
B	0.0472	0.0630	1.20	1.60	K	0.0128	0.0266	0.32	0.67
C	0.0335	0.0512	0.89	1.30	L	0.0335	0.0453	0.85	1.15
D	0.0118	0.0197	0.30	0.50	S	0.0830	0.1083	2.10	2.75
G	0.0669	0.0910	1.70	2.30	V	0.0098	0.0256	0.25	0.65
H	0.0005	0.0040	0.013	0.10					

Notes : 1.Controlling dimension : millimeters.
 2.Maximum lead thickness includes lead finish thickness, and minimum lead thickness is the minimum thickness of base material.
 3.If there is any question with packing specification or packing method, please contact your local CYStek sales office.

Material :

- Lead : Pure tin plated.
- Mold Compound : Epoxy resin family, flammability solid burning class:UL94V-0.

Important Notice:

- All rights are reserved. Reproduction in whole or in part is prohibited without the prior written approval of CYStek.
- CYStek reserves the right to make changes to its products without notice.
- **CYSrek semiconductor products are not warranted to be suitable for use in Life-Support Applications, or systems.**
- CYStek assumes no liability for any consequence of customer product design, infringement of patents, or application assistance.