

The RF Line
NPN Silicon
Low Noise, High-Frequency
Transistors

Designed for use in high gain, low noise small-signal amplifiers. This series features excellent broadband linearity and is offered in a variety of packages.

- Fully Implanted Base and Emitter Structure
- 18 Finger, 1.25 Micron Geometry with Gold Top Metal
- Gold Sintered Back Metal
- Available in tape and reel packaging options:
T1 suffix = 3,000 units per reel

MMBR951
MRF957
MRF9511
SERIES

$I_C = 100 \text{ mA}$
LOW NOISE
HIGH-FREQUENCY
TRANSISTORS

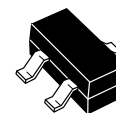

CASE 318-08, STYLE 6
SOT-23
LOW PROFILE
MMBR951LT1, MMBR951ALT1

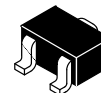

CASE 419-02, STYLE 3
MRF957T1

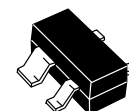

CASE 318A-05, STYLE 1
SOT-143
LOW PROFILE
MRF9511LT1

MAXIMUM RATINGS

Rating	Symbol	MMBR951LT1 MMBR951ALT1	MRF9511LT1	MRF957T1	Unit
Collector–Emitter Voltage	V_{CEO}	10	10	10	Vdc
Collector–Base Voltage	V_{CBO}	20	20	20	Vdc
Emitter–Base Voltage	V_{EBO}	1.5	1.5	15	Vdc
Power Dissipation (1) $T_C = 75^\circ\text{C}$ Derate linearly above $T_{\text{case}} = 75^\circ\text{C}$ @	$P_{D(\text{max})}$	0.322 4.29	0.322 4.29	0.227 3.03	Watts mW/°C
Collector Current — Continuous (2)	I_C	100	100	100	mA
Maximum Junction Temperature	$T_{J\text{max}}$	150	150	150	°C
Storage Temperature	T_{stg}	–55 to +150	–55 to +150	–55 to +150	°C
Thermal Resistance, Junction to Case	$R_{\theta\text{JC}}$	233	233	330	°C/W

DEVICE MARKING

MRF9511LT1 = 11	MMBR951ALT1 = AAG	MMBR951LT1 = 7Z	MRF957T1 = B
-----------------	-------------------	-----------------	--------------

ELECTRICAL CHARACTERISTICS ($T_A = 25^\circ\text{C}$ unless otherwise noted)

Characteristic	Symbol	Min	Typ	Max	Unit
----------------	--------	-----	-----	-----	------

OFF CHARACTERISTICS (3)

Collector–Emitter Breakdown Voltage ($I_C = 0.1\text{ mA}$, $I_B = 0$)	$V_{(BR)CEO}$	10	13	—	Vdc
Collector–Base Breakdown Voltage ($I_C = 0.1\text{ mA}$, $I_E = 0$)	$V_{(BR)CBO}$	20	25	—	Vdc
Emitter Cutoff Current ($V_{EB} = 1.0\text{ V}$, $I_C = 0$)	I_{EBO}	—	—	0.1	μA_{dc}
Collector Cutoff Current ($V_{CB} = 10\text{ V}$, $I_E = 0$)	I_{CBO}	—	—	0.1	μA_{dc}

ON CHARACTERISTICS (3)

DC Current Gain ($V_{CE} = 6.0\text{ V}$, $I_C = 5.0\text{ mA}$) All ($V_{CE} = 6.0\text{ V}$, $I_C = 5.0\text{ mA}$) MMBR951ALT1	h_{FE}	50 75	— —	200 150	—
---	----------	----------	--------	------------	---

DYNAMIC CHARACTERISTICS

Collector–Base Capacitance ($V_{CB} = 10\text{ V}$, $I_E = 0$, $f = 1.0\text{ MHz}$)	C_{cb}	—	0.45	1.0	pF
Current Gain — Bandwidth Product ($V_{CE} = 6.0\text{ V}$, $I_C = 30\text{ mA}$, $f = 1.0\text{ GHz}$) MRF9511LT1, MMBR951LT1, MMBR951ALT1 MRF957T1	f_T	— —	8.0 9.0	— —	GHz

NOTES:

- To calculate the junction temperature use $T_J = (P_D \times R_{\theta JA}) + T_{\text{CASE}}$. Case temperature measured on collector lead immediately adjacent to body of package.
- I_C — Continuous (MTBF ≈ 10 years).
- Pulse width $\leq 300\ \mu\text{s}$, duty cycle $\leq 2\%$ pulsed.

PERFORMANCE CHARACTERISTICS

Conditions	Symbol	MRF9511LT1			MMBR951LT1 MMBR951ALT1			MRF957T1			Unit
		Min	Typ	Max	Min	Typ	Max	Min	Typ	Max	
Insertion Gain (V _{CE} = 6.0 V, I _C = 30 mA, f = 1.0 GHz) (V _{CE} = 6.0 V, I _C = 30 mA, f = 2.0 GHz) (V _{CE} = 5.0 V, I _C = 30 mA, f = 1.5 GHz)	S ₂₁ ²	—	14.5	—	—	12.5	—	—	13.3	—	dB
Maximum Unilateral Gain (1) (V _{CE} = 8.0 V, I _C = 30 mA, f = 1.0 GHz) (V _{CE} = 8.0 V, I _C = 30 mA, f = 2.0 GHz) (V _{CE} = 5.0 V, I _C = 30 mA, f = 1.5 GHz)	G _{U max}	—	17	—	—	14	—	—	14	—	dB
Noise Figure — Minimum (Figure 9) (V _{CE} = 6.0 V, I _C = 5.0 mA, f = 1.0 GHz) (V _{CE} = 6.0 V, I _C = 5.0 mA, f = 2.0 GHz) (V _{CE} = 6.0 V, I _C = 5.0 mA, f = 1.5 GHz)	N _{F MIN}	—	1.3	—	—	1.3	—	—	1.5	—	dB
Associated Gain at Minimum NF (Figure 9) (V _{CE} = 6.0 V, I _C = 5.0 mA, f = 1.0 GHz) (V _{CE} = 6.0 V, I _C = 5.0 mA, f = 2.0 GHz) (V _{CE} = 6.0 V, I _C = 5.0 mA, f = 1.5 GHz)	G _{NF}	—	14	—	—	13	—	—	11.8	—	dB
Noise Figure — 50 ohm Source (V _{CE} = 6.0 V, I _C = 5.0 mA, f = 1.0 GHz)	N _{F50 Ω}	—	1.9	2.8	—	1.9	2.8	—	1.9	2.8	dB

NOTE:

$$1. \text{ Maximum Unilateral Gain is } G_{U\max} = \frac{|S_{21}|^2}{(1-|S_{11}|^2)(1-|S_{22}|^2)}$$

TYPICAL CHARACTERISTICS
MMBR951LT1, MMBR951ALT1, MRF9511LT1

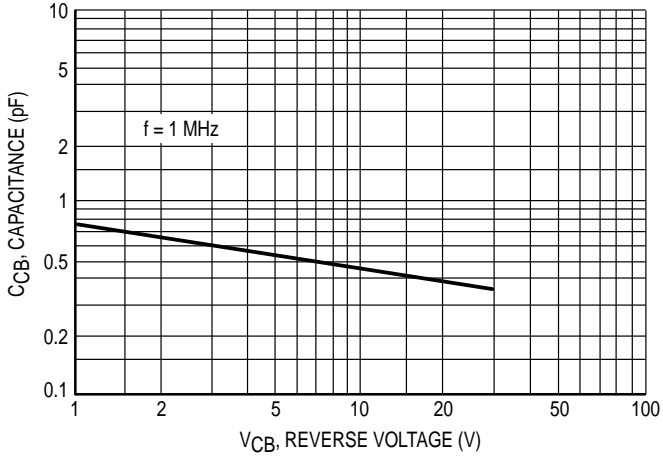

Figure 1. Collector-Base Capacitance versus Voltage

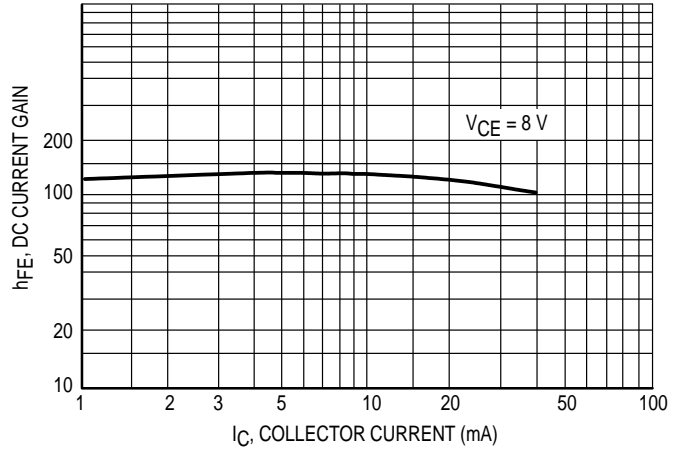

Figure 2. DC Current Gain versus Collector Current

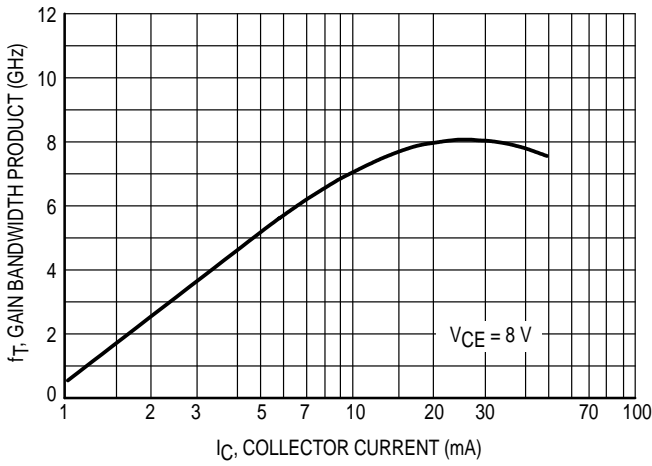

Figure 3. Gain Bandwidth Product versus Collector Current

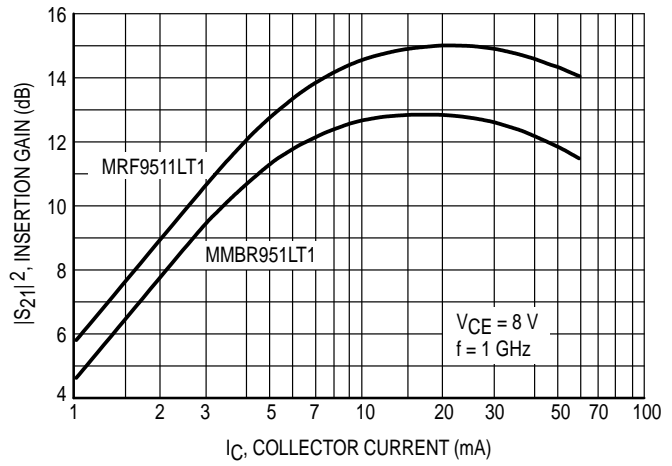

Figure 4. Insertion Gain versus Collector Current

TYPICAL FORWARD INSERTION GAIN AND MAXIMUM UNILATERAL GAIN versus FREQUENCY

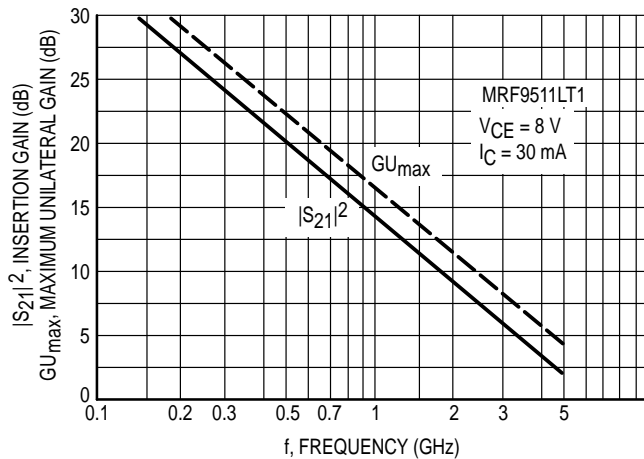

Figure 5. MRF9511LT1

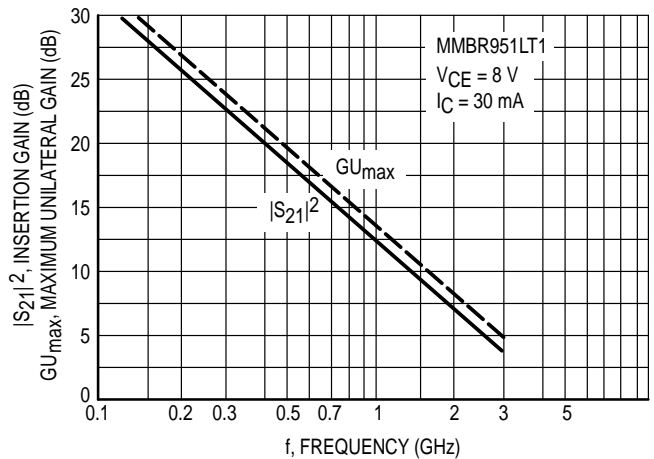

Figure 6. MMBR951LT1

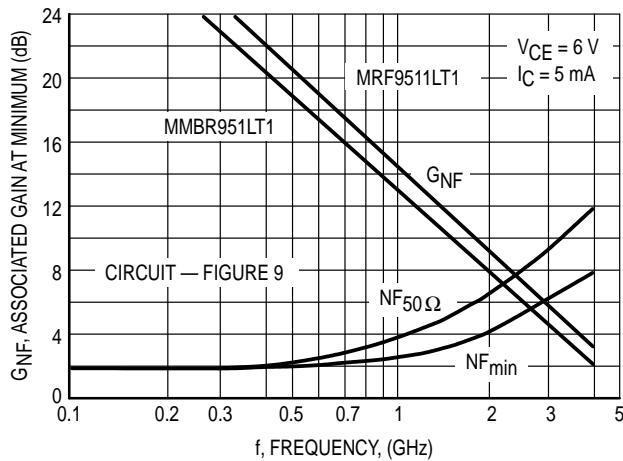

Figure 7. Typical Noise Figure and Associated Gain versus Frequency

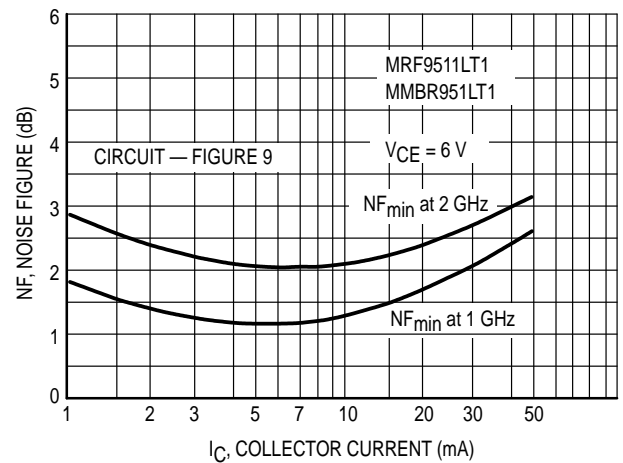

Figure 8. Typical Noise Figure versus Collector Current

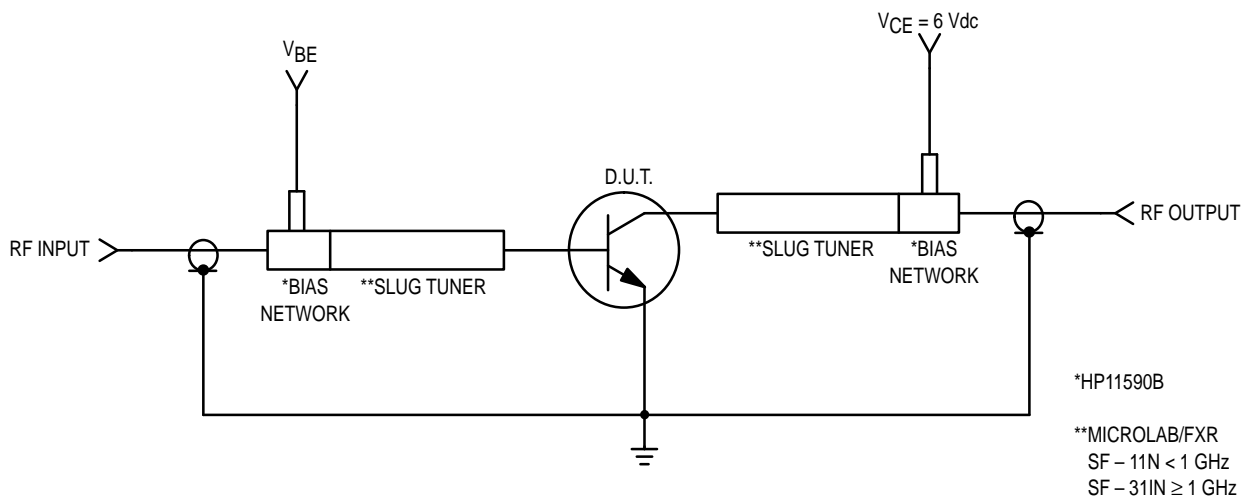

Figure 9. Functional Circuit Schematic (All Devices)

V _{CE} (Volts)	I _C (mA)	f (MHz)	S ₁₁		S ₂₁		S ₁₂		S ₂₂	
			S ₁₁	∠φ	S ₂₁	∠φ	S ₁₂	∠φ	S ₂₂	∠φ
6.0	5.0	100	0.82	-36.6	14.0	153	0.04	44.7	0.88	-18.2
		500	0.50	-119	6.6	104	0.07	48.2	0.52	-40
		1000	0.39	-162	3.5	81	0.11	55	0.43	-43
		2000	0.32	150	1.9	57	0.21	66	0.42	-50
		3000	0.36	110	1.4	40	0.31	66	0.40	-67
	10	100	0.66	-54	22.6	142	0.03	60	0.78	-29
		500	0.38	-138	7.8	96	0.07	55	0.40	-42
		1000	0.32	-176	4.0	78	0.13	71	0.34	-47
		2000	0.26	142	2.2	57	0.22	70	0.36	-46
		3000	0.31	105	1.6	41	0.32	64	0.33	-62
	20	100	0.49	-76	30	131	0.01	85	0.67	-37
		500	0.32	-153	8.3	92	0.08	76	0.34	-39
		1000	0.29	175	4.3	77	0.11	67	0.29	-44
		2000	0.24	137	2.3	57	0.24	71	0.32	-48
		3000	0.28	102	1.6	42	0.34	63	0.29	-60
	30	100	0.40	-94	33	125	0.03	87	0.58	-42
		500	0.30	-162	8.4	90	0.07	84	0.31	-35
		1000	0.29	170	4.3	76	0.12	80	0.27	-39
		2000	0.24	134	2.3	56	0.23	71	0.33	-48
		3000	0.30	101	1.6	41	0.35	66	0.30	-60
	60	100	0.38	-126	31	116	0.03	74	0.49	-37
		500	0.37	-176	7.3	77.6	0.05	84	0.34	-26
		1000	0.36	163	3.7	73.4	0.12	84	0.34	-37
		2000	0.33	130	2.0	52	0.22	78	0.37	-48
3000		0.38	98	1.4	37	0.34	69	0.34	-62	
8.0	5.0	100	0.83	-35	13.9	154	0.04	92	0.90	-19
		500	0.51	-117	6.7	104	0.08	51	0.55	-38
		1000	0.38	-160	3.6	82	0.10	72	0.44	-42
		2000	0.31	151	1.9	58	0.20	73	0.46	-47
		3000	0.35	110	1.4	41	0.32	71	0.43	-63
	10	100	0.67	-52	23	143	0.02	96	0.81	-28
		500	0.37	-135	7.9	97	0.07	64	0.43	-38
		1000	0.30	-173	4.1	80	0.11	78	0.37	-41
		2000	0.25	143	2.2	57	0.21	74	0.38	-47
		3000	0.30	105	1.6	42	0.31	67	0.34	-60
	20	100	0.51	-72	30	131	0.02	68	0.68	-35
		500	0.31	-150	8.5	92	0.07	75	0.36	-36
		1000	0.28	177	4.3	77	0.13	76	0.32	-39
		2000	0.23	138	2.3	57	0.22	72	0.35	-45
		3000	0.27	103	1.6	42	0.31	64	0.31	-58
	30	100	0.42	-87	33	125	0.02	71	0.61	-38
		500	0.31	-159	8.6	90	0.07	71	0.33	-33
		1000	0.27	172	4.4	76	0.11	74	0.32	-39
		2000	0.23	135	2.3	57	0.22	73	0.34	-42
		3000	0.28	102	1.6	41	0.31	65	0.33	-55
	60	100	0.39	-119	32	117	0.02	31	0.52	-31
		500	0.36	-174	7.4	87	0.06	84	0.37	-25
		1000	0.35	164	3.8	74	0.11	78	0.35	-33
		2000	0.32	131	2.0	53	0.22	81	0.42	-41
3000		0.37	100	1.4	38	0.33	70	0.40	-62	

Table 1. MMBR951LT1 Common Emitter S-Parameters

VCE (Vdc)	IC (mA)	f (MHz)	S11		S21		S12		S22		
			S11	∠φ	S21	∠φ	S12	∠φ	S22	∠φ	
6.0	5.0	100	0.81	-48	13.69	152	0.04	66	0.88	-22	
		500	0.67	-122	7.58	92	0.07	41	0.57	-50	
		1000	0.61	-157	4.65	76	0.09	40	0.45	-62	
		1500	0.57	86	2.87	70	0.10	44	0.42	-71	
		2000	0.54	156	2.14	60	0.12	52	0.42	-75	
		2500	0.55	121	1.72	51	0.14	57	0.40	-86	
		3000	0.57	121	1.48	44	0.17	59	0.39	-97	
		4000	0.65	110	1.28	38	0.21	60	0.37	-112	
			4000	0.67	100	1.14	33	0.24	54	0.38	-130
		10	100	0.71	-56	24.07	149	0.03	66	0.86	-28
			500	0.60	-143	9.47	101	0.05	46	0.41	-62
			1000	0.56	-176	4.97	81	0.07	51	0.30	-73
			1500	0.53	167	3.35	69	0.10	57	0.31	-78
			2000	0.50	148	2.54	60	0.13	63	0.30	-78
			2500	0.52	132	2.02	52	0.16	63	0.29	-89
			3000	0.54	116	1.75	45	0.19	61	0.29	-78
			4000	0.60	106	1.53	39	0.22	60	0.26	-115
			4000	0.64	97	1.35	34	0.26	57	0.28	-133
		20	100	0.59	-80	33.51	138	0.02	61	0.75	-38
			500	0.56	-159	10.39	95	0.04	54	0.31	-69
			1000	0.54	175	5.36	79	0.07	62	0.23	-79
			1500	0.51	161	3.58	68	0.10	66	0.25	-82
			2000	0.49	142	2.75	60	0.13	68	0.25	-80
			2500	0.52	128	2.18	52	0.16	66	0.23	-91
			3000	0.53	112	1.88	45	0.20	63	0.23	-99
			4000	0.60	103	1.65	39	0.24	62	0.21	-117
			4000	0.63	95	1.46	34	0.27	57	0.22	-137
		30	100	0.54	-97	37.48	133	0.02	57	0.67	-43
			500	0.56	-166	10.60	93	0.04	59	0.27	-70
			1000	0.54	171	5.45	78	0.07	68	0.21	-80
			1500	0.51	158	3.62	67	0.10	69	0.24	-81
			2000	0.50	140	2.73	60	0.13	70	0.23	-79
			2500	0.52	126	2.19	51	0.17	68	0.23	-90
			3000	0.53	111	1.89	45	0.20	64	0.23	-97
			4000	0.60	102	1.65	38	0.24	62	0.20	-115
			4000	0.63	94	1.47	33	0.27	58	0.22	-136
		60	100	0.54	-128	36.66	123	0.01	57	0.56	-43
			500	0.60	-177	8.97	89	0.03	67	0.27	-50
			1000	0.59	166	4.62	75	0.06	73	0.25	-59
			1500	0.56	153	3.05	64	0.09	75	0.29	-68
			2000	0.55	136	2.29	56	0.13	76	0.30	-71
			2500	0.57	125	1.85	48	0.16	74	0.29	-83
			3000	0.59	110	1.59	42	0.20	69	0.30	-92
			4000	0.65	102	1.41	36	0.23	67	0.27	-108
			4000	0.69	93	1.22	31	0.27	62	0.29	-130

(continued)

Table 2. MRF9511LT1 Common Emitter S-Parameters

V _{CE} (Vdc)	I _C (mA)	f (MHz)	S ₁₁		S ₂₁		S ₁₂		S ₂₂	
			S ₁₁	∠φ	S ₂₁	∠φ	S ₁₂	∠φ	S ₂₂	∠φ
8.0	5.0	100	0.84	-36	14.65	158	0.03	72	0.94	-18
		500	0.68	-120	7.79	110	0.07	42	0.58	-48
		1000	0.60	-161	4.32	86	0.08	41	0.44	-60
		1500	0.56	88	2.95	71	0.10	45	0.44	-68
		2000	0.53	157	2.19	60	0.11	53	0.44	-71
		2500	0.55	140	1.76	51	0.14	58	0.42	-82
		3000	0.56	122	1.50	44	0.17	60	0.42	-92
		3500	0.63	112	1.33	39	0.18	62	0.38	-107
		4000	0.68	105	1.18	33	0.21	63	0.36	-125
	10	100	0.73	-53	24.04	150	0.02	68	0.87	-26
		500	0.60	-140	9.68	101	0.05	46	0.43	-58
		1000	0.55	-174	5.10	82	0.07	52	0.32	-66
		1500	0.52	169	3.42	69	0.09	58	0.33	-72
		2000	0.49	149	2.59	61	0.12	63	0.33	-73
		2500	0.51	133	2.06	52	0.15	63	0.32	-83
		3000	0.53	116	1.78	45	0.19	63	0.32	-91
		3500	0.64	109	1.60	38	0.20	62	0.28	-108
		4000	0.67	101	1.39	34	0.23	60	0.29	-131
	20	100	0.61	-76	33.76	139	0.02	60	0.76	-36
		500	0.56	-157	10.72	96	0.04	54	0.32	-63
		1000	0.53	176	5.53	79	0.07	62	0.29	-70
		1500	0.50	162	3.69	68	0.10	66	0.27	-75
		2000	0.48	143	2.79	60	0.13	68	0.27	-74
		2500	0.51	129	2.22	52	0.16	68	0.26	-84
		3000	0.52	112	1.92	46	0.19	65	0.26	-91
		3500	0.59	104	1.75	40	0.21	64	0.24	-109
		4000	0.63	98	1.54	35	0.24	59	0.25	-131
	30	100	0.57	-89	37.35	134	0.02	58	0.71	-40
		500	0.55	-163	10.82	94	0.04	57	0.29	-63
		1000	0.53	128	5.54	78	0.07	65	0.24	-69
		1500	0.50	159	3.69	67	0.10	69	0.26	-73
		2000	0.49	141	2.77	59	0.13	70	0.27	-71
		2500	0.51	127	2.23	51	0.16	69	0.26	-82
		3000	0.52	112	1.93	45	0.19	66	0.26	-89
		3500	0.61	106	1.68	40	0.21	64	0.21	-110
		4000	0.66	97	1.51	34	0.24	60	0.23	-130
	60	100	0.55	-122	34.92	126	0.01	52	0.59	-37
		500	0.59	-175	8.71	91	0.03	65	0.33	-42
		1000	0.58	167	4.52	76	0.06	73	0.30	-53
		1500	0.55	154	3.04	65	0.09	75	0.34	-62
		2000	0.54	138	2.28	56	0.12	77	0.35	-66
		2500	0.57	125	1.82	48	0.16	76	0.34	-78
		3000	0.59	110	1.56	42	0.19	72	0.35	-88
		3500	0.66	104	1.28	36	0.22	70	0.32	-105
		4000	0.70	95	1.14	32	0.26	66	0.32	-132

Table 2. MRF9511LT1 Common Emitter S-Parameters (continued)

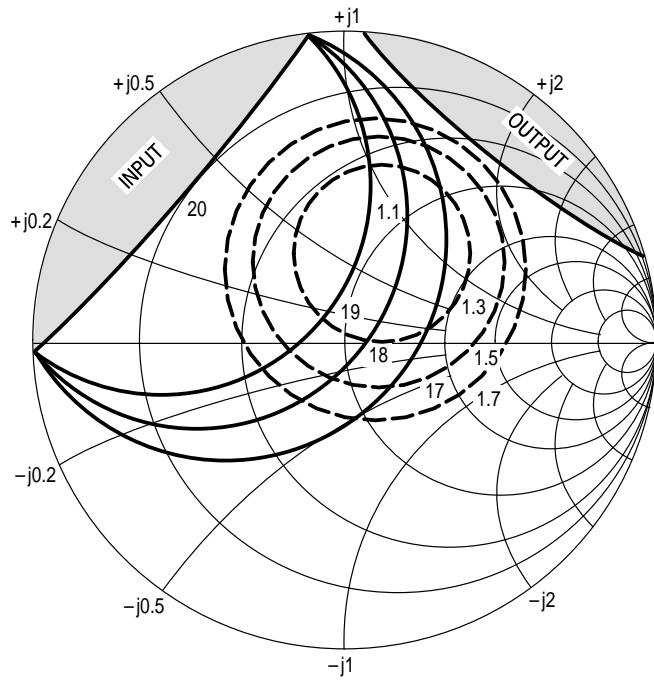

$V_{CE} = 6.0 \text{ V}$
 $I_C = 5.0 \text{ mA}$
 □ — AREA OF INSTABILITY

f (GHz)	NF OPT (dB)	Γ_{MS} NF OPT	Rn	K
0.5	1.13	$0.35 \angle 68^\circ$	9	0.68

Figure 10. MMBR951LT1 Constant Gain and Noise Figure Contours (f = 0.5 GHz)

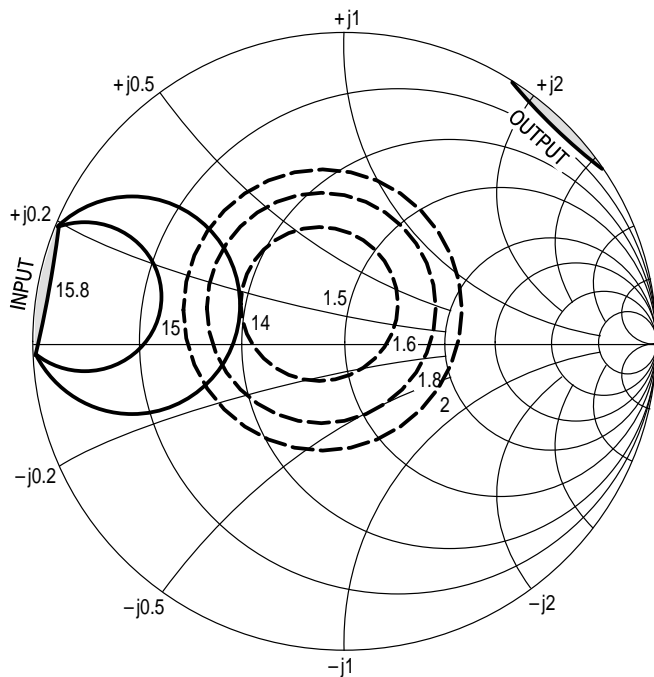

$V_{CE} = 6.0 \text{ V}$
 $I_C = 5.0 \text{ mA}$
 □ — AREA OF INSTABILITY

f (GHz)	NF OPT (dB)	Γ_{MS} NF OPT	Rn	K
1.0	1.45	$0.16 \angle 124^\circ$	8	0.97

Figure 11. MMBR951LT1 Constant Gain and Noise Figure Contours (f = 1.0 GHz)

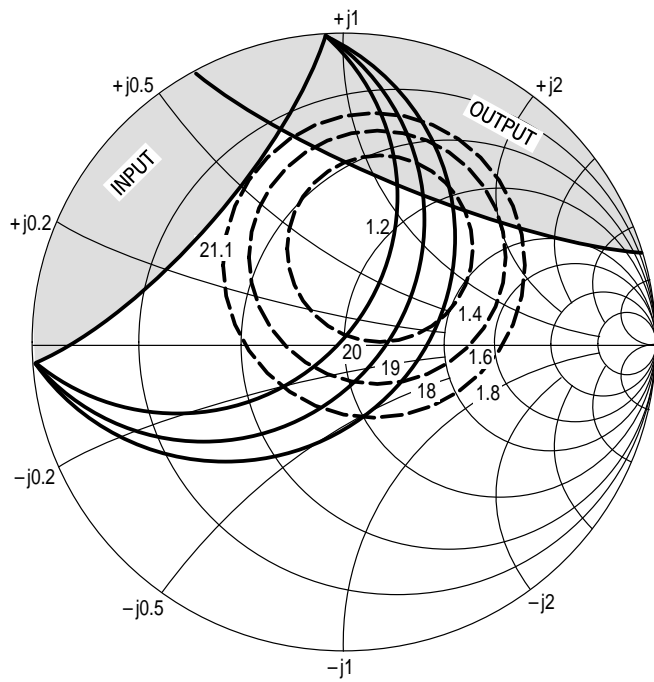

$V_{CE} = 6.0 \text{ V}$

$I_C = 5.0 \text{ mA}$

— AREA OF INSTABILITY

f (GHz)	NF OPT (dB)	Γ_{MS} NF OPT	Rn	K
0.5	1.20	$0.37 \angle 69^\circ$	10	0.42

Figure 12. MRF9511LT1 Constant Gain and Noise Figure Contours (f = 0.5 GHz)

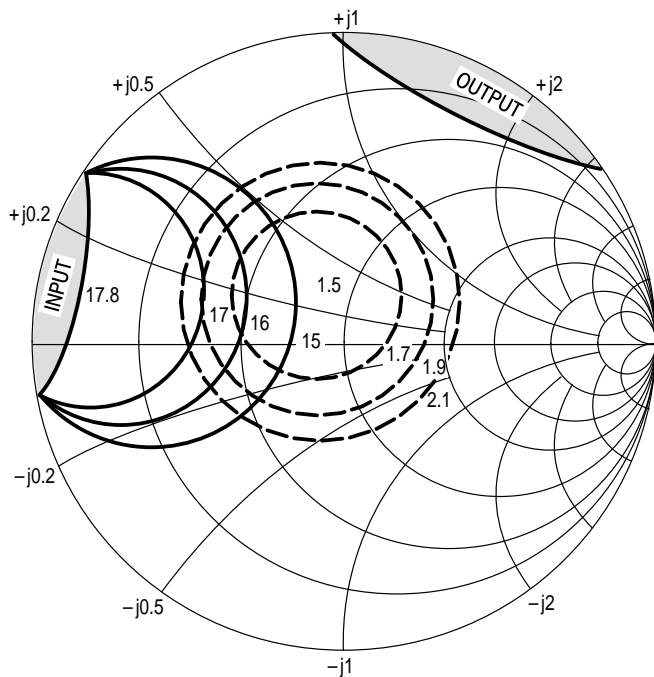

$V_{CE} = 6.0 \text{ V}$

$I_C = 5.0 \text{ mA}$

— AREA OF INSTABILITY

f (GHz)	NF OPT (dB)	Γ_{MS} NF OPT	Rn	K
1.0	1.50	$0.19 \angle 120^\circ$	9	0.74

Figure 13. MRF9511LT1 Constant Gain and Noise Figure Contours (f = 1.0 GHz)

V_{CE} (Vdc)	I_C (mA)	f (MHz)	NF _{min} (dB)	Γ_o (MAG, ANG)	r_N (ohms)
6.0	5.0	1000	1.7	0.27 \angle 97	0.2
		1500	2.0	0.21 \angle 54	0.28

Table 3. MRF957T1 Typical Noise Parameters

TYPICAL CHARACTERISTICS
MRF957T1

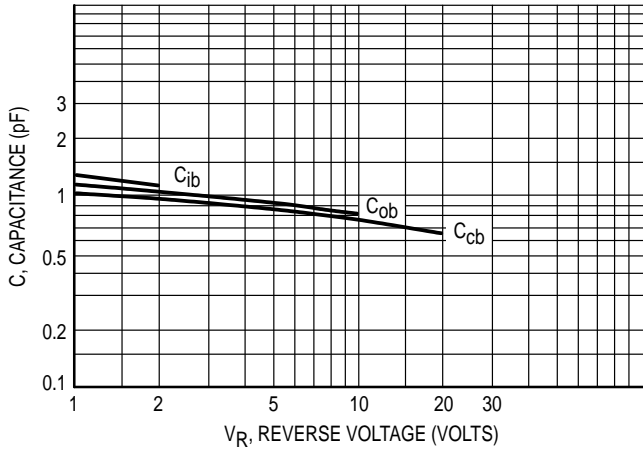

Figure 14. Capacitance versus Voltage

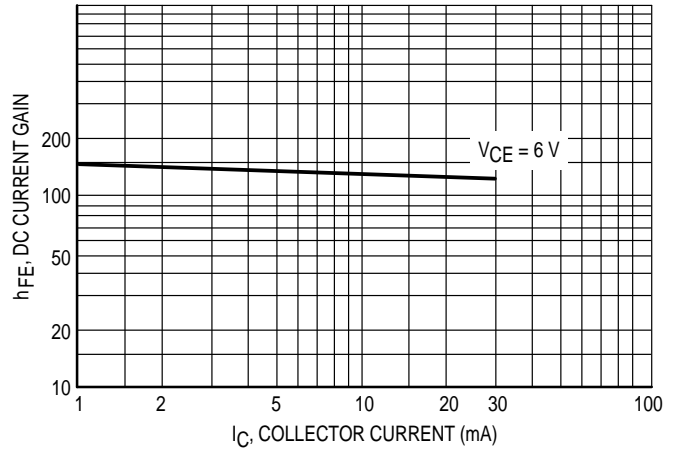

Figure 15. DC Current Gain versus Collector Current

TYPICAL CHARACTERISTICS MRF957T1

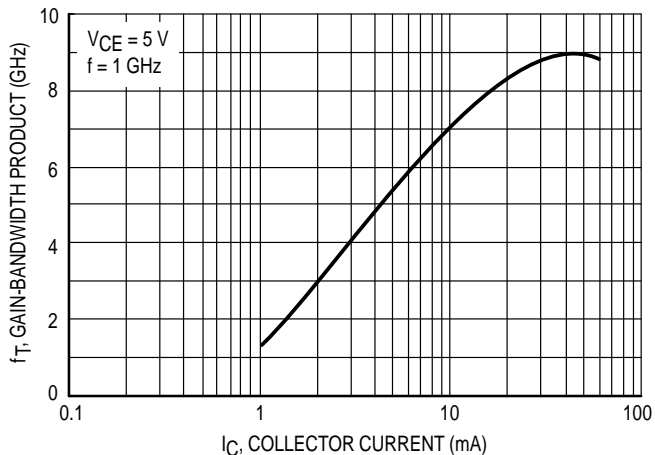

Figure 16. Gain-Bandwidth Product versus Collector Current

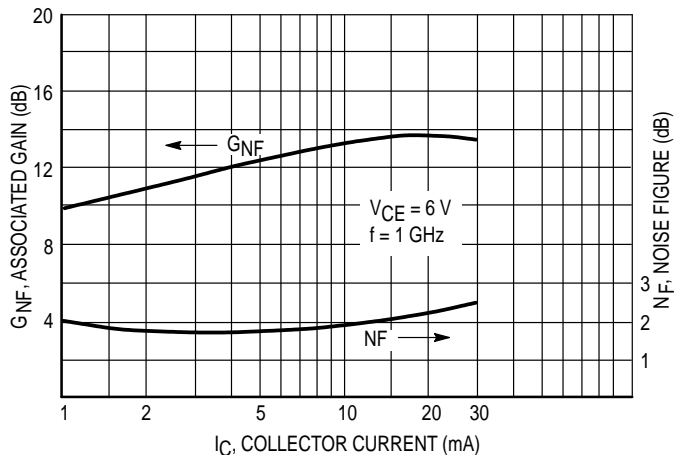

Figure 17. Associated Gain versus Collector Current

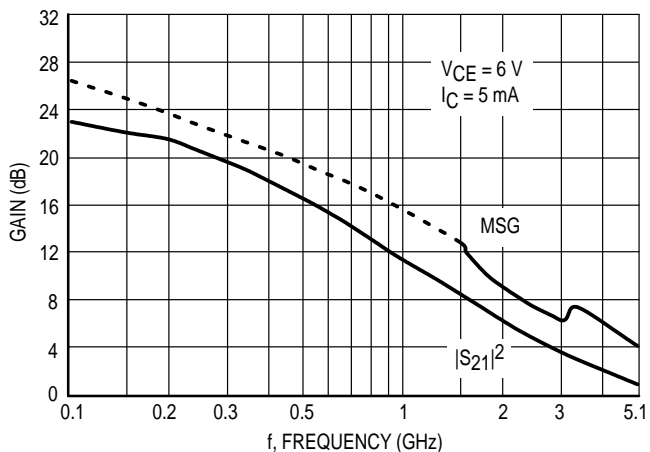

Figure 18. Insertion Gain and Maximum Stable Power Gain versus Frequency

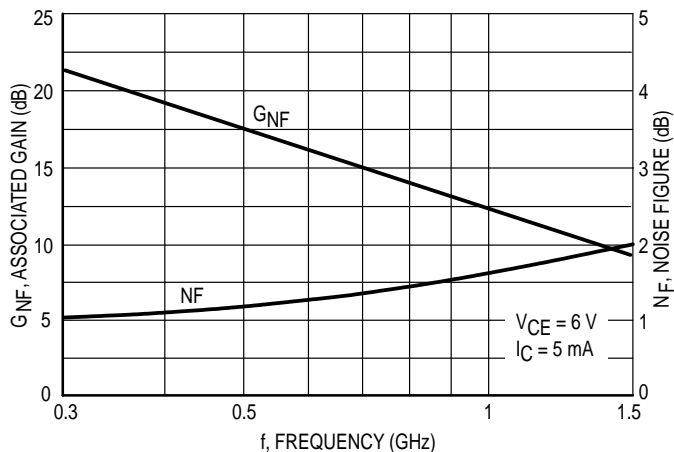
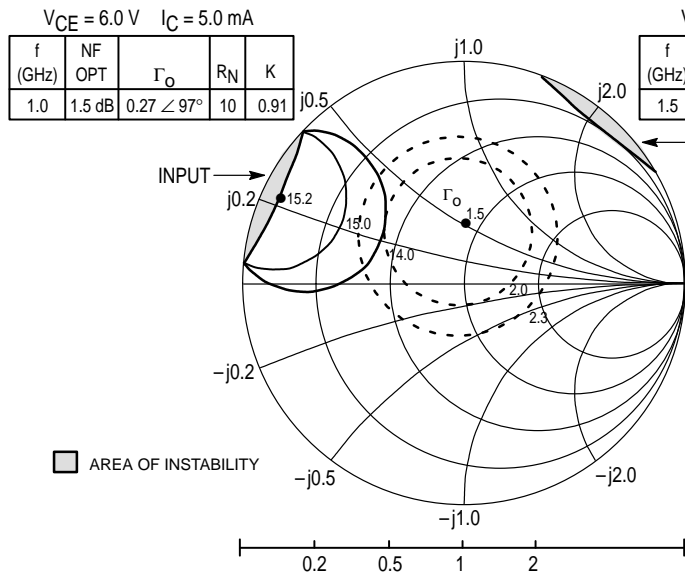
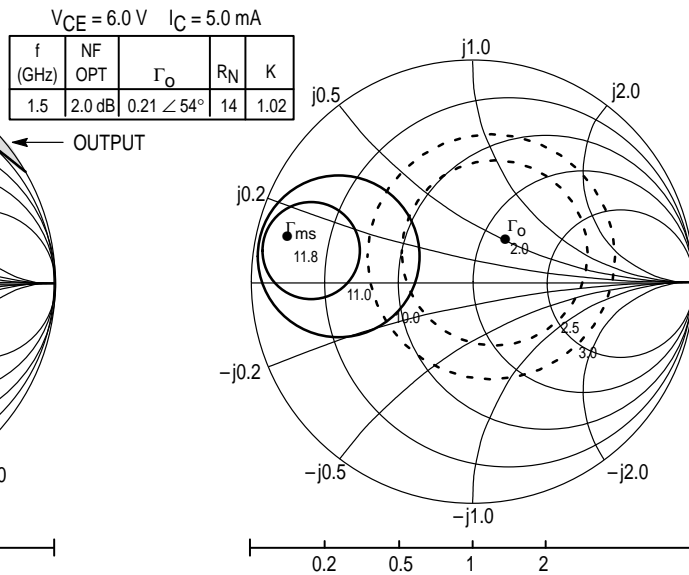

Figure 19. Noise Figure and Associated Gain versus Frequency



**Figure 20. Constant Gain and Noise Figure Contours
 $f = 1.0\text{ GHz}$**



**Figure 21. Constant Gain and Noise Figure Contours
 $f = 1.5\text{ GHz}$**

VCE (Vdc)	I _C (mA)	f (MHz)	S ₁₁		S ₂₁		S ₁₂		S ₂₂	
			S ₁₁	∠φ	S ₂₁	∠φ	S ₁₂	∠φ	S ₂₂	∠φ
2.0	1.0	100	0.959	-19.22	3.518	166.25	0.044	78.43	0.986	-8.12
		200	0.922	-38.32	3.482	153.75	0.079	69.06	0.948	-15.98
		500	0.825	-81.94	2.614	122.98	0.146	44.99	0.803	-30.02
		1000	0.690	-125.83	1.737	93.40	0.167	30.15	0.662	-41.41
		2000	0.600	-174.02	1.079	63.65	0.131	44.93	0.576	-51.42
		3000	0.640	147.15	0.791	50.62	0.196	80.39	0.517	-64.42
	2.0	100	0.922	-24.97	6.598	162.54	0.042	75.55	0.967	-12.35
		200	0.862	-48.55	6.177	147.47	0.075	64.60	0.893	-23.28
		500	0.713	-96.45	4.140	116.09	0.123	43.92	0.671	-38.55
		1000	0.586	-137.24	2.483	90.37	0.140	38.71	0.524	-46.93
		2000	0.506	179.54	1.462	64.47	0.158	57.00	0.456	-51.97
		3000	0.546	144.80	1.079	49.98	0.232	74.13	0.416	-61.22
	5.0	100	0.815	-39.45	14.163	153.09	0.038	70.19	0.895	-22.63
		200	0.708	-71.89	11.635	133.50	0.061	58.57	0.739	-38.46
		500	0.541	-121.43	6.284	104.78	0.090	49.12	0.454	-52.31
		1000	0.461	-155.05	3.428	85.44	0.123	54.90	0.337	-56.38
		2000	0.406	169.75	1.921	65.04	0.198	65.80	0.304	-54.16
		3000	0.438	139.42	1.424	51.41	0.282	69.61	0.276	-57.77
	10	100	0.667	-57.75	22.121	142.36	0.032	64.38	0.788	-34.26
		200	0.559	-95.89	15.709	121.54	0.048	57.27	0.574	-52.06
		500	0.447	-140.52	7.417	98.06	0.075	58.00	0.317	-63.32
		1000	0.405	-166.70	3.921	82.59	0.123	66.07	0.235	-65.49
		2000	0.360	162.90	2.155	65.25	0.222	69.45	0.220	-57.93
		3000	0.390	134.95	1.597	52.60	0.311	68.14	0.196	-57.79
30	100	0.435	-99.80	31.662	125.82	0.023	62.49	0.570	-51.69	
	200	0.421	-135.04	18.696	108.07	0.034	64.74	0.360	-68.74	
	500	0.398	-162.97	8.025	91.81	0.069	71.43	0.192	-75.85	
	1000	0.382	-179.33	4.163	79.67	0.127	74.17	0.151	-77.73	
	2000	0.347	155.68	2.269	64.55	0.240	72.04	0.155	-63.30	
	3000	0.379	130.21	1.686	52.60	0.336	67.80	0.132	-60.40	
60	100	0.442	-131.87	26.755	118.52	0.021	62.60	0.422	-56.23	
	200	0.483	-155.78	15.086	103.17	0.032	66.87	0.261	-70.51	
	500	0.484	-173.89	6.390	88.79	0.067	74.30	0.154	-73.64	
	1000	0.472	172.69	3.317	76.81	0.127	76.73	0.140	-74.96	
	2000	0.452	149.80	1.834	60.68	0.243	72.97	0.155	-66.57	
	3000	0.496	126.23	1.393	48.59	0.345	68.81	0.131	-71.10	

(continued)

Table 4. MRF957T1 Typical Common Emitter S-Parameters

MRF957T1

V _{CE} (Vdc)	I _C (mA)	f (MHz)	S ₁₁		S ₂₁		S ₁₂		S ₂₂	
			S ₁₁	∠φ	S ₂₁	∠φ	S ₁₂	∠φ	S ₂₂	∠φ
5.0	1.0	100	0.965	-17.73	3.508	167.36	0.035	78.18	0.990	-6.80
		200	0.931	-35.39	3.495	155.78	0.065	71.66	0.958	-13.35
		500	0.835	-77.08	2.680	126.50	0.122	48.12	0.839	-25.23
		1000	0.694	-120.78	1.820	97.22	0.143	33.67	0.713	-35.51
		2000	0.583	-170.80	1.133	67.35	0.115	50.88	0.629	-44.48
		3000	0.615	148.45	0.813	53.19	0.182	85.71	0.565	-55.47
	2.0	100	0.932	-22.38	6.532	164.05	0.034	77.81	0.975	-9.92
		200	0.875	-44.00	6.217	150.00	0.061	67.15	0.914	-18.98
		500	0.726	-89.77	4.314	119.58	0.106	47.42	0.724	-31.79
		1000	0.582	-131.10	2.638	93.76	0.122	41.23	0.586	-39.20
		2000	0.483	-176.30	1.544	67.35	0.140	60.85	0.521	-43.55
		3000	0.515	146.92	1.117	52.27	0.208	78.88	0.479	-51.26
	5.0	100	0.836	-34.35	14.112	155.49	0.031	71.72	0.920	-18.06
		200	0.731	-63.59	11.971	137.05	0.052	61.40	0.785	-31.06
		500	0.539	-112.00	6.737	107.93	0.080	51.32	0.522	-41.63
		1000	0.438	-147.18	3.710	88.06	0.110	57.59	0.408	-43.94
		2000	0.364	175.10	2.050	67.58	0.175	68.31	0.383	-42.49
		3000	0.392	142.26	1.501	53.59	0.251	73.36	0.357	-45.46
	10	100	0.704	-49.02	22.526	145.79	0.027	67.46	0.831	-27.03
		200	0.577	-83.93	16.647	125.23	0.042	59.78	0.634	-41.45
		500	0.421	-129.59	8.120	100.71	0.069	60.52	0.385	-47.31
		1000	0.361	-158.62	4.290	84.82	0.109	67.54	0.305	-46.57
		2000	0.307	168.57	2.330	67.52	0.196	71.46	0.305	-42.00
		3000	0.332	137.50	1.706	54.85	0.277	71.05	0.288	-42.21
	20	100	0.559	-66.34	30.018	136.00	0.023	64.88	0.720	-35.45
		200	0.453	-103.91	19.598	116.12	0.036	61.80	0.501	-48.64
		500	0.358	-143.87	8.835	96.19	0.064	68.23	0.298	-49.15
		1000	0.324	-167.05	4.595	83.08	0.112	72.95	0.247	-47.12
2000		0.278	163.88	2.462	67.27	0.208	72.96	0.263	-41.09	
3000		0.306	133.94	1.809	55.45	0.291	70.31	0.249	-39.38	
30	100	0.492	-73.65	32.055	131.68	0.022	64.17	0.669	-37.70	
	200	0.412	-110.53	20.121	113.25	0.033	64.60	0.459	-49.28	
	500	0.345	-147.89	8.900	94.88	0.062	69.52	0.278	-48.58	
	1000	0.319	-169.39	4.646	82.13	0.113	74.20	0.234	-46.64	
	2000	0.277	162.38	2.492	67.55	0.210	73.10	0.255	-40.63	
	3000	0.305	133.57	1.821	55.24	0.295	70.42	0.239	-38.73	

Table 4. MRF957T1 Typical Common Emitter S-Parameters (continued)

PACKAGE DIMENSIONS

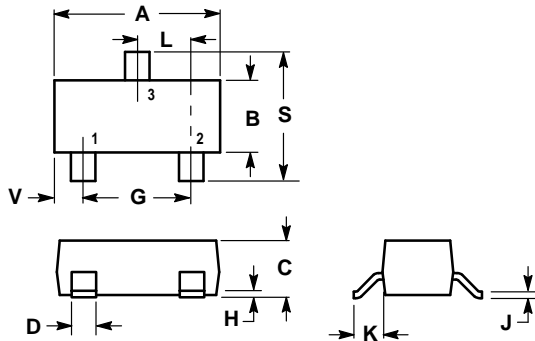

NOTES:

1. DIMENSIONING AND TOLERANCING PER ANSI Y14.5M, 1982.
2. CONTROLLING DIMENSION: INCH.
3. MAXIMUM LEAD THICKNESS INCLUDES LEAD FINISH THICKNESS. MINIMUM LEAD THICKNESS IS THE MINIMUM THICKNESS OF BASE MATERIAL.

DIM	INCHES		MILLIMETERS	
	MIN	MAX	MIN	MAX
A	0.1102	0.1197	2.80	3.04
B	0.0472	0.0551	1.20	1.40
C	0.0350	0.0440	0.89	1.11
D	0.0150	0.0200	0.37	0.50
G	0.0701	0.0807	1.78	2.04
H	0.0005	0.0040	0.013	0.100
J	0.0034	0.0070	0.085	0.177
K	0.0140	0.0285	0.35	0.69
L	0.0350	0.0401	0.89	1.02
S	0.0830	0.1039	2.10	2.64
V	0.0177	0.0236	0.45	0.60

STYLE 6:

- PIN 1. BASE
2. EMITTER
3. COLLECTOR

**CASE 318-08
ISSUE AF
MMBR951LT1, MMBR951ALT1**

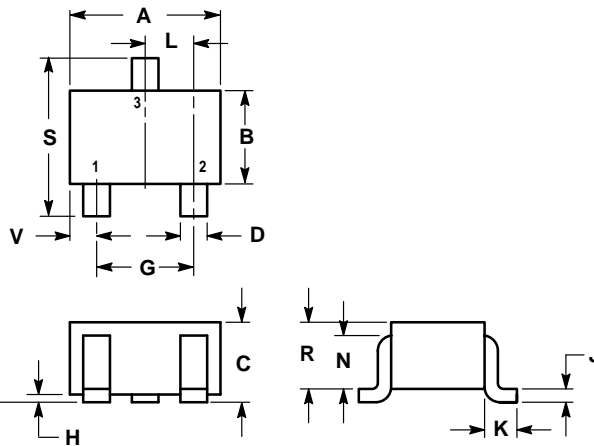

NOTES:

1. DIMENSIONING AND TOLERANCING PER ANSI Y14.5M, 1982.
2. CONTROLLING DIMENSION: INCH.

DIM	INCHES		MILLIMETERS	
	MIN	MAX	MIN	MAX
A	0.071	0.087	1.80	2.20
B	0.045	0.053	1.15	1.35
C	0.035	0.049	0.90	1.25
D	0.012	0.016	0.30	0.40
G	0.047	0.055	1.20	1.40
H	0.000	0.004	0.00	0.10
J	0.004	0.010	0.10	0.25
K	0.017 REF		0.425 REF	
L	0.026 BSC		0.650 BSC	
N	0.028 REF		0.700 REF	
R	0.031	0.039	0.80	1.00
S	0.079	0.087	2.00	2.20
V	0.012	0.016	0.30	0.40

STYLE 3:

- PIN 1. BASE
2. EMITTER
3. COLLECTOR

**CASE 419-02
ISSUE J
MRF957T1**

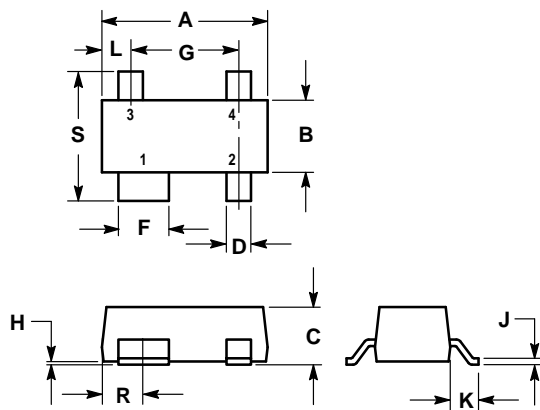

NOTES:
 4. DIMENSIONING AND TOLERANCING PER ANSI Y14.5M, 1982.
 5. CONTROLLING DIMENSION: MILLIMETER.

DIM	MILLIMETERS		INCHES	
	MIN	MAX	MIN	MAX
A	2.80	3.04	0.110	0.120
B	1.20	1.39	0.047	0.055
C	0.84	1.14	0.033	0.045
D	0.39	0.50	0.015	0.020
F	0.79	0.93	0.031	0.037
G	1.78	2.03	0.070	0.080
H	0.013	0.10	0.0005	0.004
J	0.08	0.15	0.003	0.006
K	0.46	0.60	0.018	0.024
L	0.445	0.60	0.0175	0.024
R	0.72	0.83	0.028	0.033
S	2.11	2.48	0.083	0.098

STYLE 1:
 PIN 1. COLLECTOR
 2. EMITTER
 3. EMITTER
 4. BASE

**CASE 318A-05
 ISSUE R
 MRF9511LT1**

Motorola reserves the right to make changes without further notice to any products herein. Motorola makes no warranty, representation or guarantee regarding the suitability of its products for any particular purpose, nor does Motorola assume any liability arising out of the application or use of any product or circuit, and specifically disclaims any and all liability, including without limitation consequential or incidental damages. "Typical" parameters which may be provided in Motorola data sheets and/or specifications can and do vary in different applications and actual performance may vary over time. All operating parameters, including "Typicals" must be validated for each customer application by customer's technical experts. Motorola does not convey any license under its patent rights nor the rights of others. Motorola products are not designed, intended, or authorized for use as components in systems intended for surgical implant into the body, or other applications intended to support or sustain life, or for any other application in which the failure of the Motorola product could create a situation where personal injury or death may occur. Should Buyer purchase or use Motorola products for any such unintended or unauthorized application, Buyer shall indemnify and hold Motorola and its officers, employees, subsidiaries, affiliates, and distributors harmless against all claims, costs, damages, and expenses, and reasonable attorney fees arising out of, directly or indirectly, any claim of personal injury or death associated with such unintended or unauthorized use, even if such claim alleges that Motorola was negligent regarding the design or manufacture of the part. Motorola and  are registered trademarks of Motorola, Inc. Motorola, Inc. is an Equal Opportunity/Affirmative Action Employer.

Mfax is a trademark of Motorola, Inc.

How to reach us:

USA/EUROPE/Locations Not Listed: Motorola Literature Distribution;
 P.O. Box 5405, Denver, Colorado 80217. 1-303-675-2140 or 1-800-441-2447

JAPAN: Nippon Motorola Ltd.: SPD, Strategic Planning Office, 141,
 4-32-1 Nishi-Gotanda, Shagawa-ku, Tokyo, Japan. 03-5487-8488

Customer Focus Center: 1-800-521-6274

Mfax™: RMFAX0@email.sps.mot.com – TOUCHTONE 1-602-244-6609
 Motorola Fax Back System – US & Canada ONLY 1-800-774-1848
 – http://sps.motorola.com/mfax/

ASIA/PACIFIC: Motorola Semiconductors H.K. Ltd.; 8B Tai Ping Industrial Park,
 51 Ting Kok Road, Tai Po, N.T., Hong Kong. 852-26629298

HOME PAGE: <http://motorola.com/sps/>

