

TOSHIBA CMOS Digital Integrated Circuit Silicon Monolithic

# TC7SP3066TU, TC7SP3067TU

TC7SP3066TU Low Voltage Dual Supply Single Bus Switch (analog)

TC7SP3067TU Low Voltage Dual Supply Single Bus Switch (analog)

The TC7SP3066 and TC7SP3067 are high-speed CMOS one-bit analog bus switches with separate power supplies for control and switch portions. In the TC7SP3066, the switch is on when Output Enable (OE) is High. In the TC7SP3067, the switch is on when Output Enable ( $\overline{OE}$ ) is Low.

The TC7SP3066 and TC7SP3067 support power-down protection by incorporating 3.6-V-tolerant control inputs.

These devices are suitable for applications where the control voltage is lower than the signal line voltage.

All inputs are equipped with protection circuits against static discharge or transient excess voltage.

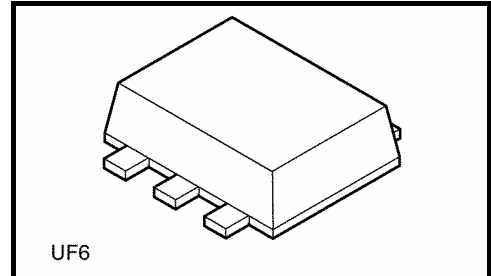

Weight: 0.007 g (typ.)

## Features

- Operating voltage range:
  - $V_{CCA} = 1.1$  to  $2.7$  V (Control portion)
  - $V_{CCB} = 1.65$  to  $3.6$  V (Switch portion)
- ON-resistance:  $R_{ON} = 8 \Omega$  (max) ( $V_{CCB} = 2.7$  V)  
 $R_{ON} = 10 \Omega$  (max) ( $V_{CCB} = 2.3$  V)
- ESD performance: Machine model  $\geq \pm 200$  V  
Human body model  $\geq \pm 2000$  V
- Ultra-small package: UF6
- 3.6-V tolerance function and power-down protection at the Output Enable input.

## Pin Assignment (top view)

TC7SP3066TU

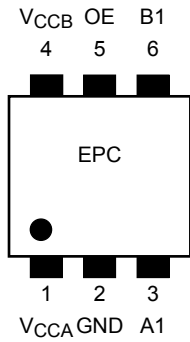

TC7SP3067TU

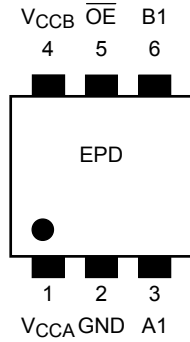

## Truth Table

Input (3066)	Function	Input (3067)	Function
OE		$\overline{OE}$	
H	Aport = Bport	H	Disconnected
L	Disconnected	L	Aport = Bport

## Circuit Schematic

TC7SP3066TU

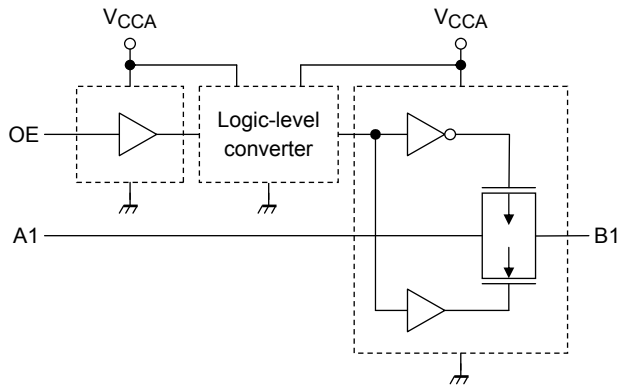

TC7SP3067TU

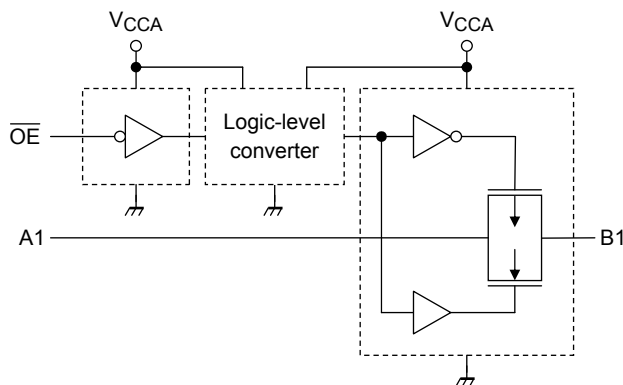

## Absolute Maximum Ratings (Note 1)

Characteristics	Symbol	Rating	Unit
Power supply voltage (Note 2)	$V_{CCA}$	-0.5 to 4.6	V
	$V_{CCB}$	-0.5 to 4.6	
Control input voltage (OE (3066)/ OE (3067))	$V_{IN}$	-0.5 to 4.6	V
Switch input/output voltage	$V_S$	-0.5 to $V_{CCB} + 0.5$	V
Diode current in the control portion	$I_{IK}$	-25	mA
Diode current in the switch portion	$I_{IK}$	±50 (Note 3)	mA
Switch input/output current	$I_S$	128	mA
DC $V_{CC}$ /ground current	$I_{CCA}$	±50	mA
	$I_{CCB}$	±100	
Power dissipation	$P_D$	200	mW
Storage temperature	$T_{stg}$	-65 to 150	°C

Note 1: Exceeding any of the absolute maximum ratings, even briefly, lead to deterioration in IC performance or even destruction.

Using continuously under heavy loads (e.g. the application of high temperature/current/voltage and the significant change in temperature, etc.) may cause this product to decrease in the reliability significantly even if the operating conditions (i.e. operating temperature/current/voltage, etc.) are within the absolute maximum ratings and the operating ranges.

Please design the appropriate reliability upon reviewing the Toshiba Semiconductor Reliability Handbook ("Handling Precautions"/"Derating Concept and Methods") and individual reliability data (i.e. reliability test report and estimated failure rate, etc).

Note 2: Do not supply a voltage to the  $V_{CCB}$  pin when  $V_{CCA}$  is in the OFF state.

Note 3:  $V_S < GND$ ,  $V_S > V_{CCB}$

## Operating Ranges (Note)

Characteristics	Symbol	Rating	Unit
Power supply voltage	$V_{CCA}$	1.1 to 2.7	V
	$V_{CCB}$	1.65 to 3.6	
Control input voltage	$V_{IN}$	0 to 3.6	V
Switch input/output voltage	$V_S$	0 to $V_{CCB}$	V
Operating temperature	$T_{opr}$	-40 to 85	°C
Control input rise and fall times	dt/dv	0 to 10	ns/V

Note: The operating ranges must be maintained to ensure the normal operation of the device. Unused inputs must be tied to either  $V_{CCA}$  or GND.

## Electrical Characteristics

### DC Characteristics (1.1 V ≤ V<sub>CCA</sub> ≤ 2.7 V, 1.65 V ≤ V<sub>CCB</sub> ≤ 3.6 V)

Characteristics	Symbol	Test Condition		V <sub>CCA</sub> (V)	V <sub>CCB</sub> (V)	Ta = -40 to 85°C		Unit
						Min	Max	
High-level input voltage	V <sub>IH</sub>	OE (3066), $\overline{OE}$ (3067)		1.1 ≤ V <sub>CCA</sub> < 1.4	1.65 to 3.6	0.70 × V <sub>CCA</sub>	—	V
				1.4 ≤ V <sub>CCA</sub> < 1.65	1.65 to 3.6	0.70 × V <sub>CCA</sub>	—	V
				1.65 ≤ V <sub>CCA</sub> < 2.3	2.3 to 3.6	0.70 × V <sub>CCA</sub>	—	V
				2.3 ≤ V <sub>CCA</sub> ≤ 2.7	2.7 to 3.6	1.6	—	V
Low-level input voltage	V <sub>IL</sub>	OE (3066), $\overline{OE}$ (3067)		1.1 ≤ V <sub>CCA</sub> < 1.4	1.65 to 3.6	—	0.30 × V <sub>CCA</sub>	V
				1.4 ≤ V <sub>CCA</sub> < 1.65	1.65 to 3.6	—	0.30 × V <sub>CCA</sub>	V
				1.65 ≤ V <sub>CCA</sub> < 2.3	2.3 to 3.6	—	0.30 × V <sub>CCA</sub>	V
				2.3 ≤ V <sub>CCA</sub> ≤ 2.7	2.7 to 3.6	—	0.7	V
ON-resistance (Note)	R <sub>ON</sub>	V <sub>IS</sub> = 0 V	I <sub>S</sub> = 30 mA	1.1 to 2.7	2.7	—	8	Ω
		V <sub>IS</sub> = 2.7 V	I <sub>S</sub> = 30 mA	1.1 to 2.7	2.7	—	12	
		V <sub>IS</sub> = 2.1 V	I <sub>S</sub> = 15 mA	1.1 to 2.7	2.7	—	20	
		V <sub>IS</sub> = 0 V	I <sub>S</sub> = 24 mA	1.1 to 2.3	2.3	—	10	
		V <sub>IS</sub> = 2.3 V	I <sub>S</sub> = 24 mA	1.1 to 2.3	2.3	—	15	
		V <sub>IS</sub> = 2.0 V	I <sub>S</sub> = 15 mA	1.1 to 2.3	2.3	—	25	
Switch-off leakage current	I <sub>SZ</sub>	A1, B1 = 0 to V <sub>CCB</sub> $\overline{OE}$ = V <sub>CCA</sub> , OE = GND		1.1 to 2.7	1.65 to 3.6	—	±2.0	μA
Control input current	I <sub>IN</sub>	$\overline{OE}$ or OE = 0 to 3.6 V		1.1 to 2.7	1.65 to 3.6	—	±1.0	μA
Quiescent supply current	I <sub>CCA</sub>	V <sub>IN</sub> = V <sub>CCA</sub> or GND, I <sub>S</sub> = 0 A		1.1 to 2.7	1.65 to 3.6	—	4.0	μA
	I <sub>CCB</sub>	V <sub>IN</sub> = V <sub>CCA</sub> or GND, I <sub>S</sub> = 0 A		1.1 to 2.7	1.65 to 3.6	—	4.0	
	I <sub>CCA</sub>	V <sub>CCA</sub> ≤ V <sub>IN</sub> ≤ 3.6 V, I <sub>S</sub> = 0 A		1.1 to 2.7	1.65 to 3.6	—	4.0	
	I <sub>CCB</sub>	V <sub>CCA</sub> ≤ V <sub>IN</sub> ≤ 3.6 V, I <sub>S</sub> = 0 A		1.1 to 2.7	1.65 to 3.6	—	4.0	

Note: ON-resistance is measured by measuring the voltage drop across the switch at the indicated current. V<sub>IS</sub> is defined as the lower voltage at the A and B pins.

## AC Characteristics (Ta = -40 to 85°C, Input: tr = tf = 2.0 ns)

**VCCA = 2.5 ± 0.2 V, VCCB = 3.3 ± 0.3 V**

Characteristics	Symbol	Test Condition	Min	Max	Unit
Propagation delay time (bus to bus)	t <sub>pLH</sub> t <sub>pHL</sub>	Figures 1 and 2 (Note)	—	0.25	ns
3-state output enable time	t <sub>pZL</sub> t <sub>pZH</sub>	Figures 1 and 3	—	7	
3-state output disable time	t <sub>pLZ</sub> t <sub>pHZ</sub>	Figures 1 and 3	—	7	

Note: Calculated from the RC time constant of the ON-resistance of the output and the capacitive load.

**VCCA = 1.8 ± 0.15 V, VCCB = 3.3 ± 0.3 V**

Characteristics	Symbol	Test Condition	Min	Max	Unit
Propagation delay time (bus to bus)	t <sub>pLH</sub> t <sub>pHL</sub>	Figures 1 and 2 (Note)	—	0.25	ns
3-state output enable time	t <sub>pZL</sub> t <sub>pZH</sub>	Figures 1 and 3	—	9	
3-state output disable time	t <sub>pLZ</sub> t <sub>pHZ</sub>	Figures 1 and 3	—	9	

Note: Calculated from the RC time constant of the ON-resistance of the output and the capacitive load.

**VCCA = 1.5 ± 0.1 V, VCCB = 3.3 ± 0.3 V**

Characteristics	Symbol	Test Condition	Min	Max	Unit
Propagation delay time (bus to bus)	t <sub>pLH</sub> t <sub>pHL</sub>	Figures 1 and 2 (Note)	—	0.25	ns
3-state output enable time	t <sub>pZL</sub> t <sub>pZH</sub>	Figures 1 and 3	—	12	
3-state output disable time	t <sub>pLZ</sub> t <sub>pHZ</sub>	Figures 1 and 3	—	12	

Note: Calculated from the RC time constant of the ON-resistance of the output and the capacitive load.

**VCCA = 1.2 ± 0.1 V, VCCB = 3.3 ± 0.3 V**

Characteristics	Symbol	Test Condition	Min	Max	Unit
Propagation delay time (bus to bus)	t <sub>pLH</sub> t <sub>pHL</sub>	Figures 1 and 2 (Note)	—	0.25	ns
3-state output enable time	t <sub>pZL</sub> t <sub>pZH</sub>	Figures 1 and 3	—	20	
3-state output disable time	t <sub>pLZ</sub> t <sub>pHZ</sub>	Figures 1 and 3	—	20	

Note: Calculated from the RC time constant of the ON-resistance of the output and the capacitive load.

$$V_{CCA} = 1.8 \pm 0.15 \text{ V}, V_{CCB} = 2.5 \pm 0.2 \text{ V}$$

Characteristics	Symbol	Test Condition	Min	Max	Unit
Propagation delay time (bus to bus)	$t_{pLH}$ $t_{pHL}$	Figures 1 and 2 (Note)	—	0.61	ns
3-state output enable time	$t_{pZL}$ $t_{pZH}$	Figures 1 and 3	—	11	
3-state output disable time	$t_{pLZ}$ $t_{pHZ}$	Figures 1 and 3	—	11	

Note: Calculated from the RC time constant of the ON-resistance of the output and the capacitive load.

$$V_{CCA} = 1.5 \pm 0.1 \text{ V}, V_{CCB} = 2.5 \pm 0.2 \text{ V}$$

Characteristics	Symbol	Test Condition	Min	Max	Unit
Propagation delay time (bus to bus)	$t_{pLH}$ $t_{pHL}$	Figures 1 and 2 (Note)	—	0.61	ns
3-state output enable time	$t_{pZL}$ $t_{pZH}$	Figures 1 and 3	—	12	
3-state output disable time	$t_{pLZ}$ $t_{pHZ}$	Figures 1 and 3	—	12	

Note: Calculated from the RC time constant of the ON-resistance of the output and the capacitive load.

$$V_{CCA} = 1.2 \pm 0.1 \text{ V}, V_{CCB} = 2.5 \pm 0.2 \text{ V}$$

Characteristics	Symbol	Test Condition	Min	Max	Unit
Propagation delay time (bus to bus)	$t_{pLH}$ $t_{pHL}$	Figures 1 and 2 (Note)	—	0.61	ns
3-state output enable time	$t_{pZL}$ $t_{pZH}$	Figures 1 and 3	—	17	
3-state output disable time	$t_{pLZ}$ $t_{pHZ}$	Figures 1 and 3	—	17	

Note: Calculated from the RC time constant of the ON-resistance of the output and the capacitive load.

$$V_{CCA} = 1.2 \pm 0.1 \text{ V}, V_{CCB} = 1.8 \pm 0.15 \text{ V}$$

Characteristics	Symbol	Test Condition	Min	Max	Unit
Propagation delay time (bus to bus)	$t_{pLH}$ $t_{pHL}$	Figures 1 and 2 (Note)	—	1.15	ns
3-state output enable time	$t_{pZL}$ $t_{pZH}$	Figures 1 and 3	—	25	
3-state output disable time	$t_{pLZ}$ $t_{pHZ}$	Figures 1 and 3	—	25	

Note: Calculated from the RC time constant of the ON-resistance of the output and the capacitive load.

**Capacitive Characteristics (Ta = 25°C)**

Characteristics	Symbol	Test Condition	VCCB (V)		Typ.	Unit
			VCCA (V)	VCCB (V)		
Control input capacitance	C <sub>IN</sub>		2.5	3.3	7	pF
Switch input/output capacitance	C <sub>I/O</sub>	$\overline{OE} = V_{CCA}, OE = GND$	2.5	3.3	10	pF

**AC Test Circuit**

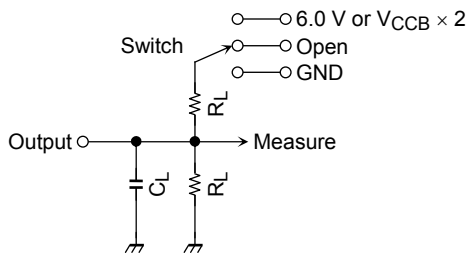

Parameter	Switch
t <sub>pLH</sub> , t <sub>pHL</sub>	Open
t <sub>pLZ</sub> , t <sub>pZL</sub>	6.0 V @ VCCB = 3.3 ± 0.3 V
	VCCB × 2 @ VCCB = 2.5 ± 0.2 V
	@ VCCB = 1.8 ± 0.15 V
t <sub>pHZ</sub> , t <sub>pZH</sub>	GND

Symbol	VCCB (output)	
	3.3 ± 0.3 V 2.5 ± 0.2 V	1.8 ± 0.15 V
R <sub>L</sub>	500 Ω	1 kΩ
C <sub>L</sub>	30 pF	30 pF

**Figure 1**

**AC Test Waveform**

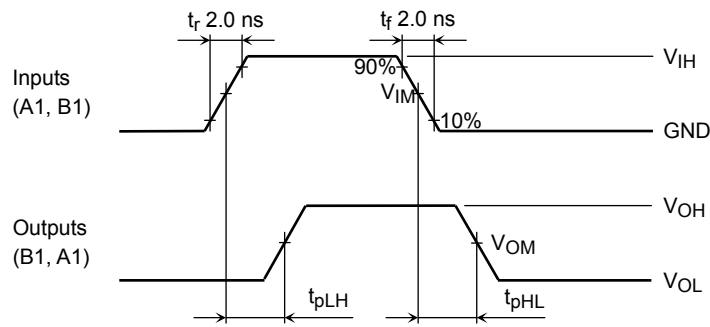

**Figure 2**  $t_{pLH}$ ,  $t_{pHL}$

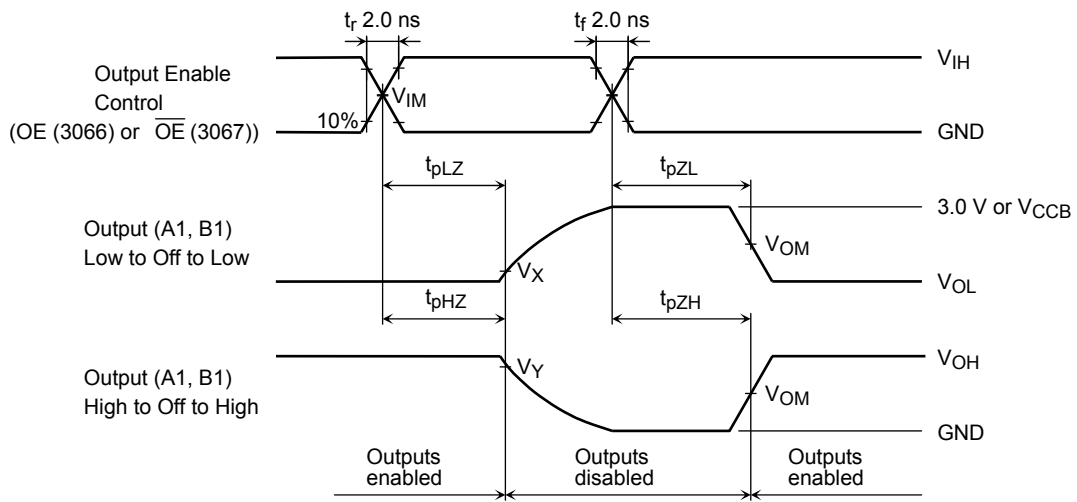

**Figure 3**  $t_{pLZ}$ ,  $t_{pHZ}$ ,  $t_{pZL}$ ,  $t_{pZH}$

	Symbol	$V_{CCA}$ or $V_{CCB}$		
		$3.3 \pm 0.3$ V	$2.5 \pm 0.2$ V $1.8 \pm 0.15$ V	$1.5 \pm 0.1$ V $1.2 \pm 0.1$ V
Input	$V_{IH}$	—	$V_{CCA}$	$V_{CCA}$
	$V_{IM}$	—	$V_{CCA}/2$	$V_{CCA}/2$
Output	$V_{OM}$	$V_{OH}/2$	$V_{OH}/2$	—
	$V_X$	$V_{OL} + 0.3$ V	$V_{OL} + 0.15$ V	—
	$V_Y$	$V_{OH} - 0.3$ V	$V_{OH} - 0.15$ V	—



**Package Dimensions**

UF6

Unit: mm

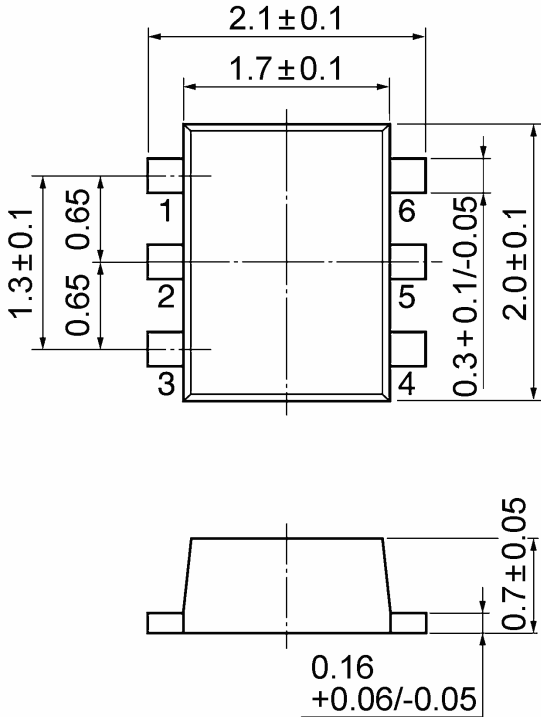

Weight: 0.007 g (typ.)

**RESTRICTIONS ON PRODUCT USE**

20070701-EN GENERAL

- The information contained herein is subject to change without notice.
- TOSHIBA is continually working to improve the quality and reliability of its products. Nevertheless, semiconductor devices in general can malfunction or fail due to their inherent electrical sensitivity and vulnerability to physical stress. It is the responsibility of the buyer, when utilizing TOSHIBA products, to comply with the standards of safety in making a safe design for the entire system, and to avoid situations in which a malfunction or failure of such TOSHIBA products could cause loss of human life, bodily injury or damage to property.  
In developing your designs, please ensure that TOSHIBA products are used within specified operating ranges as set forth in the most recent TOSHIBA products specifications. Also, please keep in mind the precautions and conditions set forth in the "Handling Guide for Semiconductor Devices," or "TOSHIBA Semiconductor Reliability Handbook" etc.
- The TOSHIBA products listed in this document are intended for usage in general electronics applications (computer, personal equipment, office equipment, measuring equipment, industrial robotics, domestic appliances, etc.). These TOSHIBA products are neither intended nor warranted for usage in equipment that requires extraordinarily high quality and/or reliability or a malfunction or failure of which may cause loss of human life or bodily injury ("Unintended Usage"). Unintended Usage include atomic energy control instruments, airplane or spaceship instruments, transportation instruments, traffic signal instruments, combustion control instruments, medical instruments, all types of safety devices, etc.. Unintended Usage of TOSHIBA products listed in this document shall be made at the customer's own risk.
- The products described in this document shall not be used or embedded to any downstream products of which manufacture, use and/or sale are prohibited under any applicable laws and regulations.
- The information contained herein is presented only as a guide for the applications of our products. No responsibility is assumed by TOSHIBA for any infringements of patents or other rights of the third parties which may result from its use. No license is granted by implication or otherwise under any patents or other rights of TOSHIBA or the third parties.
- Please contact your sales representative for product-by-product details in this document regarding RoHS compatibility. Please use these products in this document in compliance with all applicable laws and regulations that regulate the inclusion or use of controlled substances. Toshiba assumes no liability for damage or losses occurring as a result of noncompliance with applicable laws and regulations.