

TC3W03FU

CRYSTAL OSCILLATOR

The TC3W03FU is a IC for high speed CMOS crystal oscillator fabricated with silicon gate C²MOS technology. It can be used to make high efficient crystal oscillator with certain output signal by added external crystal oscillation unit, some capacitor and resistor. It has selective 4-step (f_0 , $1/2f_0$, $1/4f_0$, $1/8f_0$) frequency divide down function. And by setting the disable oscillate input (CE) to low level, the output (Q) becomes high impedance. All inputs are equipped with protection circuits against static discharge or transient excess voltage.

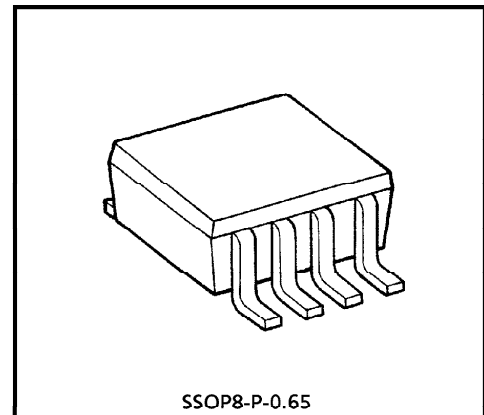

Weight : 0.02g (Typ.)

FEATURES

- Wide oscillation frequency range ... $f_{osc} = 1\text{MHz} \sim 40\text{MHz}$
- Incorporated frequency divide down step
... selective f_0 , $1/2f_0$, $1/4f_0$ or $1/8f_0$
- 3-state output
- Output drive capability ... 10 LSTTL loads
- Very small package

MAXIMUM RATINGS

PARAMETER	SYMBOL	VALUE	UNIT
Supply Voltage Range	V_{CC}	-0.5~7.0	V
DC Input Voltage	V_{IN}	-0.5~ $V_{CC} + 0.5$	V
DC Output Voltage	V_{OUT}	-0.5~ $V_{CC} + 0.5$	V
Input Diode Current	I_{IN}	± 20	mA
Output Diode Current	I_{OUT}	± 25	mA
Power Dissipation	P_C	300	mW
Storage Temperature	T_{stg}	-65~150	°C
Lead Temperature (10s)	T_L	260	°C

MARKING

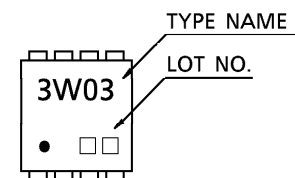

PIN ASSIGNMENT (TOP VIEW)

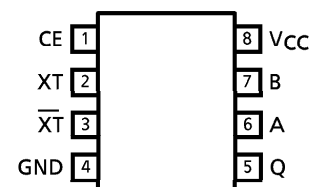

(Note)

This IC is used only for crystal oscillation. So, this is unfit for DC~low frequency range operation and frequency divide down.

961001EBA2

● TOSHIBA is continually working to improve the quality and the reliability of its products. Nevertheless, semiconductor devices in general can malfunction or fail due to their inherent electrical sensitivity and vulnerability to physical stress. It is the responsibility of the buyer, when utilizing TOSHIBA products, to observe standards of safety, and to avoid situations in which a malfunction or failure of a TOSHIBA product could cause loss of human life, bodily injury or damage to property. In developing your designs, please ensure that TOSHIBA products are used within specified operating ranges as set forth in the most recent products specifications. Also, please keep in mind the precautions and conditions set forth in the TOSHIBA Semiconductor Reliability Handbook.

TRUTH TABLE

INPUTS			OUTPUTS
CE	A	B	Q
H	L	L	f_0
	L	H	$1/2f_0$
	H	L	$1/4f_0$
	H	H	$1/8f_0$
L	Don't care		Z

Z : High impedance

PIN DESIGNATIONS

PIN NO.	SYMBOL	FUNCTION
1	CE	Disable oscillate and Reset
2	XT	Connect to crystal unit dvide down step.
3	\overline{XT}	Connect to crystal unit dvide down step.
4	GND	Ground
5	Q	Output
6	A	Select for devide down ratio
7	B	Select for devide down ratio
8	V _{CC}	Supply voltage

RECOMMENDED OPERATING CONDITIONS

PARAMETER	SYMBOL	VALUE	UNIT
Supply Voltage	V _{CC}	5 ± 0.5	V
Input Voltage	V _{IN}	0~V _{CC}	V
Operating Temperature	T _{opr}	-45~85	°C

DC ELECTRICAL CHARACTERISTICS

PARAMETER	SYMBOL	TEST CIR-CUIT	TEST CONDITION	Ta = 25°C			Ta = -40~85°C		UNIT
				MIN.	TYP.	MAX.	MIN.	MAX.	
High-Level Input Voltage	V _{IH}	—	V _{CC} = 5V	3.5	—	—	3.5	—	V
Low-Level Input Voltage	V _{IL}	—	V _{CC} = 5V	—	—	1.5	—	1.5	V
High-Level Output Current	I _{OH}	—	V _{CC} = 5V	-4.0	—	—	-3.8	—	mA
Low-Level Output Current	I _{OL}	—	V _{CC} = 5V	4.0	—	—	3.8	—	mA
High-Level Input Current	I _{IH}	—	CE = A = B = V _{CC}	—	—	0.1	—	1.0	μA
Low-Level Input Current	I _{IL}	—	A = B = GND	—	—	-0.1	—	-1.0	μA
Quiescent Supply Current	I _{CC}	—	CE = V _{CC} , A = B = GND	—	—	1.0	—	10	μA
Stand by Current	I _{STN}	—	CE = GND	—	—	500	—	700	μA
3-State Output Off-State Current	I _{OZ}	—	A = B = V _{IH} or V _{IL} V _{OZ} = V _{CC} or GND	—	—	± 0.5	—	± 5.0	μA
Builtin Pull-up Resistor	R _{CE}	—	—	154	220	286	154	286	kΩ

AC ELECTRICAL CHARACTERISTICS (V_{CC} = 5V, Ta = 25°C)

PARAMETER	SYMBOL	TEST CIR-CUIT	TEST CONDITION	MIN.	TYP.	MAX.	UNIT
Operating Current	I _{CC(opr)}	—	See application circuit	—	—	22	mA
Operating Frequency Range	f _{opr}	—	See application circuit	1.0	—	40	MHz
Output Wave form Duty	Duty	—	See application circuit	45	50	55	%

961001EBA2'

- The products described in this document are subject to foreign exchange and foreign trade control laws.
- The information contained herein is presented only as a guide for the applications of our products. No responsibility is assumed by TOSHIBA CORPORATION for any infringements of intellectual property or other rights of the third parties which may result from its use. No license is granted by implication or otherwise under any intellectual property or other rights of TOSHIBA CORPORATION or others.
- The information contained herein is subject to change without notice.

APPLICATION CIRCUIT (Example)

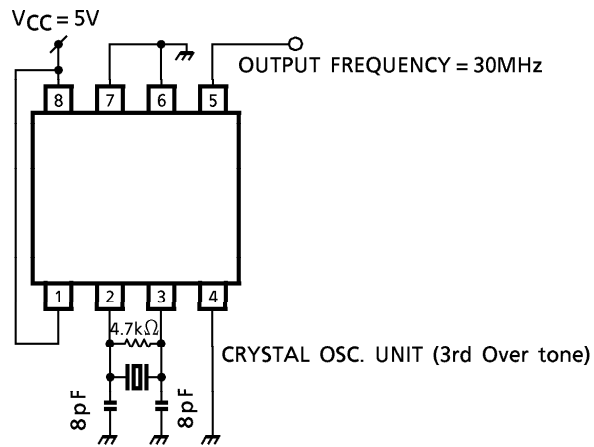

SYSTEM DIAGRAM

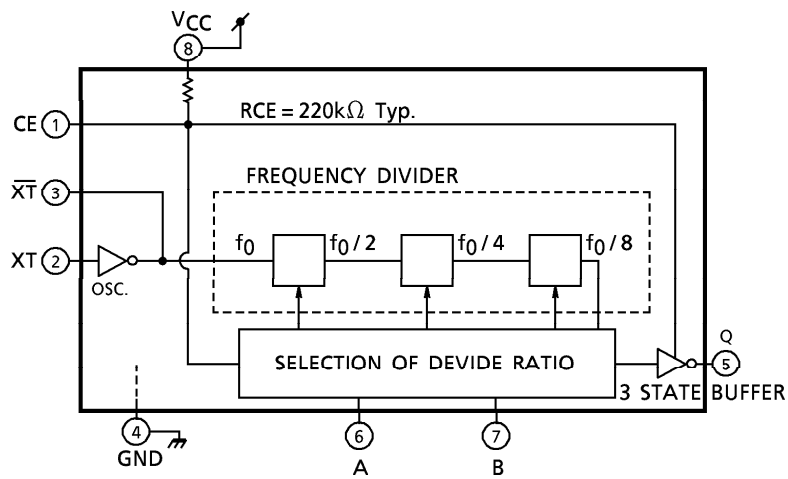

OUTLINE DRAWING
SSOP8-P-0.65

Unit : mm

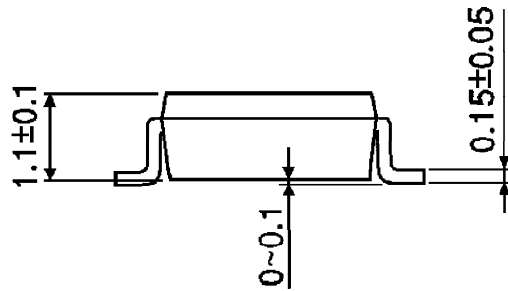
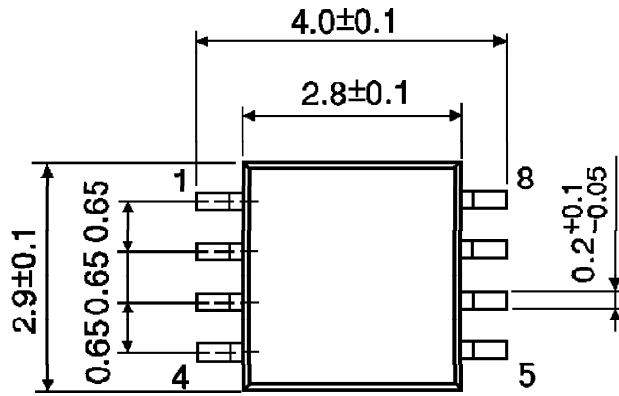

Weight : 0.02g (Typ.)