

#### BUS BUFFER, 3-STATE OUTPUT

#### FEATURES

- High Output Drive :  $\pm 24\text{mA}$  (Typ.) @ $V_{CC}=3\text{V}$
- Super High Speed Operation :  $t_{PD}=2.6\text{ns}$ (Typ.) @ $V_{CC}=5\text{V}$ , 50pF
- Operation Voltage Range :  $V_{CC(\text{opr})}=1.8 \sim 5.5\text{V}$ .

#### MAXIMUM RATINGS (Ta=25 °C)

CHARACTERISTIC	SYMBOL	RATING	UNIT
Supply Voltage Range	$V_{CC}$	-0.5 ~ 6	V
DC Input Voltage	$V_{IN}$	-0.5 ~ 6	V
DC Output Voltage	$V_{OUT}$	-0.5 ~ 6	V
Input Diode Current	$I_{IK}$	$\pm 20$	mA
Output Diode Current	$I_{OK}$	$\pm 20$	mA
DC Output Current	$I_{OUT}$	$\pm 50$	mA
DC $V_{CC}$ /Ground Current	$I_{CC}$	$\pm 50$	mA
Power Dissipation	$P_D$	200	mW
Storage Temperature	$T_{stg}$	-65 ~ 150	°C
Lead Temperature (10s)	$T_L$	260	°C

#### LOGIC DIAGRAM

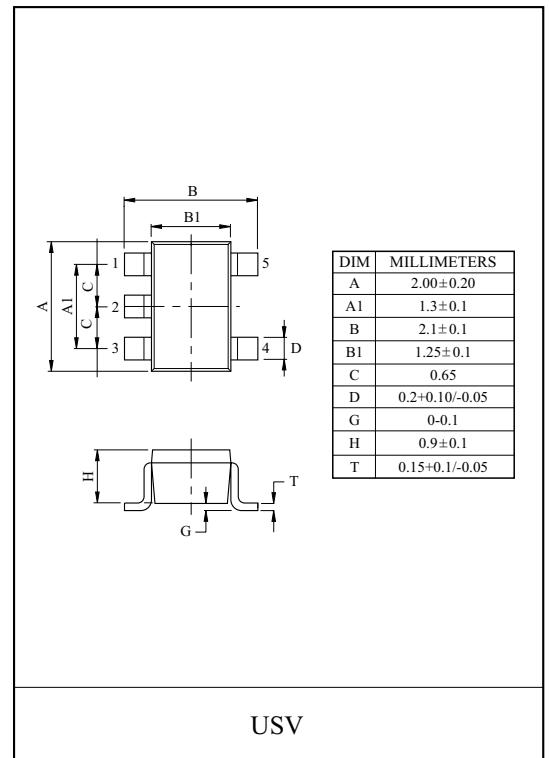
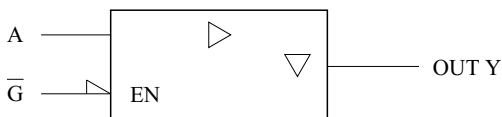

#### MARKING

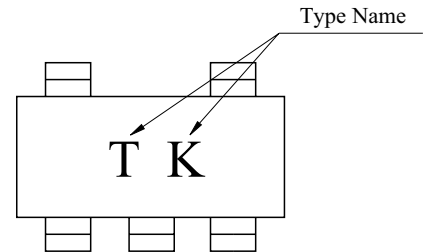

#### PIN CONNECTION(TOP VIEW)

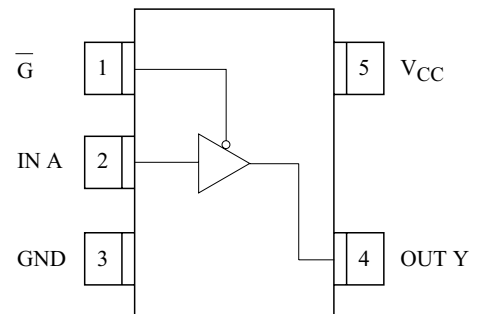

# KIC7SZ125FU

## RECOMMENDED OPERATING CONDITIONS

CHARACTERISTIC	SYMBOL	RATING	UNIT
Supply Voltage	$V_{CC}$	1.8 ~ 5.5	V
		1.5 ~ 5.5 (Note1)	
Input Voltage	$V_{IN}$	0 ~ 5.5	V
Output Voltage	$V_{OUT}$	0 ~ 5.5 (Note2)	V
		0 ~ $V_{CC}$ (Note3)	
Operating Temperature	$T_{opr}$	-40 ~ 85	°C
Input Rise and Fall Time	dt/dv	0 ~ 20 ( $V_{CC}=1.8V, 2.5V \pm 0.2V$ )	ns/V
		0 ~ 10 ( $V_{CC}=3.3V \pm 0.3V$ )	
		0 ~ 5 ( $V_{CC}=5.5V \pm 0.5V$ )	

Note1) Data retention only. Note2)  $V_{CC}=0V$  Note3) H and Low state

## DC ELECTRICAL CHARACTERISTICS

CHARACTERISTIC	SYMBOL	TEST CONDITION	$V_{CC}(V)$	$T_a=25^\circ C$			$T_a=-40 \sim 85^\circ C$		UNIT	
				MIN.	TYP.	MAX.	MIN.	MAX.		
High-Level Input Voltage	$V_{IH}$	-	1.8	0.88 $\times V_{CC}$	-	-	0.88 $\times V_{CC}$	-	V	
			2.3 ~ 5.5	0.75 $\times V_{CC}$	-	-	0.75 $\times V_{CC}$	-		
Low-Level Input Voltage	$V_{IL}$	-	1.8	-	-	0.12 $\times V_{CC}$	-	0.12 $\times V_{CC}$	V	
			2.3 ~ 5.5	-	-	0.25 $\times V_{CC}$	-	0.25 $\times V_{CC}$		
High-Level Output Voltage	$V_{OH}$	$V_{IN}=V_{IH}$ or $V_{IL}$	$I_{OH}=-100\mu A$	1.8	1.7	1.8	-	1.7	-	V
				2.3	2.2	2.3	-	2.2	-	
				3.0	2.9	3.0	-	2.9	-	
				4.5	4.4	4.5	-	4.4	-	
			$I_{OH}=-8mA$	2.3	1.9	2.15	-	1.9	-	
			$I_{OH}=-16mA$	3.0	2.4	2.8	-	2.4	-	
			$I_{OH}=-24mA$	3.0	2.3	2.68	-	2.3	-	
$I_{OH}=-32mA$	4.5	3.8	4.2	-	3.8	-				
Low-Level Output Voltage	$V_{OL}$	$V_{IN}=V_{IH}$ or $V_{IL}$	$I_{OL}=100\mu A$	1.8	-	0	0.1	-	0.1	V
				2.3	-	0	0.1	-	0.1	
				3.0	-	0	0.1	-	0.1	
				4.5	-	0	0.1	-	0.1	
			$I_{OL}=8mA$	2.3	-	0.1	0.3	-	0.3	
			$I_{OL}=16mA$	3.0	-	0.15	0.4	-	0.4	
			$I_{OL}=24mA$	3.0	-	0.22	0.55	-	0.55	
$I_{OL}=32mA$	4.5	-	0.22	0.55	-	0.55				
Input Leakage Current	$I_{IN}$	$V_{IN}=5.5V$ or GND	0 ~ 5.5	-	-	$\pm 1$	-	$\pm 10$	$\mu A$	
3-state Output off-State Current	$I_{OZ}$	$V_{IN}=V_{IH}$ or $V_{IL}$ $V_{OUT}=0 \sim 5.5V$	1.8 ~ 5.5	-	-	$\pm 1$	-	$\pm 10$		
Quiescent Supply Current	$I_{CC}$	$V_{IN}=V_{CC}$ or GND	5.5	-	-	2	-	20		

# KIC7SZ125FU

## AC ELECTRICAL CHARACTERISTICS (Input $t_r=t_f=3ns$ )

CHARACTERISTIC	SYMBOL	TEST CONDITION	Ta=25 °C			Ta=-40 ~85 °C		UNIT	
			V <sub>CC</sub> (V)	MIN.	TYP.	MAX.	MIN.		MAX.
Propagation Delay Time	$t_{PLH}$ $t_{PHL}$	$C_L=15pF$ , $R_L=1M\Omega$ (Figure 1)	1.8	2.0	5.3	11.0	2.0	11.5	ns
			$2.5 \pm 0.2$	0.8	3.4	7.5	0.8	8.0	
			$3.3 \pm 0.3$	0.5	2.5	5.2	0.5	5.5	
			$5.0 \pm 0.5$	0.5	2.1	4.5	0.5	4.8	
		$C_L=50pF$ , $R_L=500\Omega$ (Figure 1)	$3.3 \pm 0.3$	1.5	3.2	5.7	1.5	6.0	
			$5.0 \pm 0.5$	0.8	2.6	5.0	0.8	5.3	
Output Enable Time	$t_{PZL}$ $t_{PZH}$	$C_L=50pF$ , $R_L=500\Omega$ (Figure 1)	1.8	2.0	7.0	12.5	2.0	13.0	ns
			$2.5 \pm 0.2$	1.5	4.6	8.0	1.5	9.0	
			$3.3 \pm 0.3$	1.5	3.5	6.2	1.5	6.5	
			$5.0 \pm 0.5$	0.8	2.8	5.5	0.8	5.8	
Output Disable Time	$t_{PZL}$ $t_{PZH}$	$C_L=50pF$ , $R_L=500\Omega$ (Figure 1)	1.8	2.0	5.4	11.0	2.0	12.0	ns
			$2.5 \pm 0.2$	1.5	3.5	8.0	1.5	8.5	
			$3.3 \pm 0.3$	1.0	2.8	5.7	1.0	6.0	
			$5.0 \pm 0.5$	0.5	2.1	4.7	0.5	5.0	
Input Capacitance	$C_{IN}$	-	0 ~5.5	-	4	-	-	-	pF
Power Dissipation Capacitance	$C_{PD}$	(Note 1)	3.3	-	17	-	-	-	pF
			3.5	-	24	-	-	-	

Note 1 :  $C_{PD}$  defined as the value of internal equivalent capacitance of IC which is calculated from the operating current consumption without load (refer to Test Circuit.) Average operating current can be obtained by the equation hereunder.

$$I_{CC(opr)} = C_{PD} \cdot V_{CC} \cdot f_{IN} + I_{CC}$$

Fig. 1 AC CHARACTERISTICS MEASUREMENT CIRCUIT

