

TENTATIVE

Features and Applications

- Low ON-state resistance.
- Very high-speed switching.
- 4V drive.

Absolute Maximum Ratings / Ta=25°C

			unit
Drain to Source Voltage	VDSS	30	V
Gate to Source Voltage	VGSS	±24	V
Drain Current (DC)	ID	2.2	A
Drain Current (Pulse)	IDP	PW≤10μs, duty cycle≤1%	10
Allowable power Dissipation	PD	Mounted on ceramic board(900mm ² × 0.8mm)	1
Channel Temperature	Tch	150	°C
Storage Temperature	Tstg	-55 to +150	°C

Electrical Characteristics / Ta=25°C

			min	typ	max	unit
Drain to Source Breakdown Voltage	V(BR)DSS	ID=1mA, VGS=0	30			V
Zero Gate Voltage Drain Current	IDSS	VDS=30V, VGS=0			10	μA
Gate to Source Leakage Current	IGSS	VGS=±16V, VDS=0			±10	μA
Cutoff Voltage	VGS(off)	VDS=10V, ID=1mA	1.0		2.4	V
Forward Transfer Admittance	yfs	VDS=10V, ID=1A	1.4	2.0		S
Static Drain to Source on State Resistance	RDS(on) 1	ID=1A, VGS=10V		115	150	mΩ
	RDS(on) 2	ID=500mA, VGS=4V		230	320	mΩ
Input Capacitance	Ciss	VDS=10V, f=1MHz		125	175	pF
Output Capacitance	Coss	VDS=10V, f=1MHz		80	110	pF
Reverse Transfer Capacitance	Crss	VDS=10V, f=1MHz		35	50	pF
Turn-ON Delay Time	td(on)	See specified Test Circuit		7	14	ns
Rise Time	tr	"		6	12	ns
Turn-off Delay Time	td(off)	"		18	36	ns
Fall Time	tf	"		11	22	ns
Total Gate Charge	Qg	VDS=10V, VGS=10V, ID=2.2A		5.6	8.4	nC
Gate Source Charge	Qgs			1.4		nC
Gate Drain Charge	Qgd			1.4		nC
Diode Forward Voltage	VSD	IS=2.2A, VGS=0	1.0	1.2		V

Marking : KD

Switching Time Test Circuit

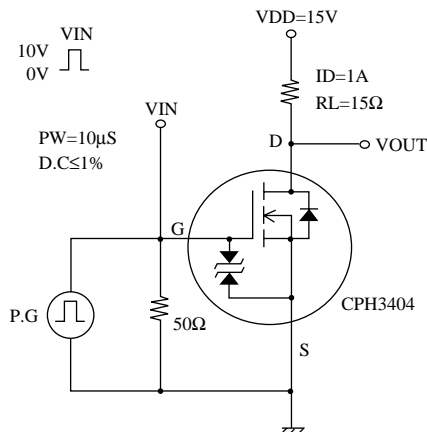

Package Dimensions CPH3(unit:mm)

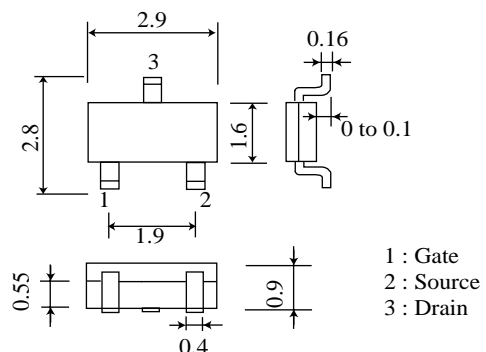

Specifications and information herein are subject to change without notice.

SANYO Electric Co., Ltd. Semiconductor Company

TOKYO OFFICE Tokyo Bldg., 1-10,1 Chome, Ueno, taito-ku, 110 JAPAN

990915TM2FXHD