

Description

The SFC2280-10 is a low pass filter array with integrated TVS diodes. It is designed to provide bidirectional filtering of EMI/RFI signals and electrostatic discharge (ESD) protection in portable electronic equipment. This state-of-the-art device utilizes solid-state silicon-avalanche technology for superior clamping performance and DC electrical characteristics. They have been optimized for use on a speaker port in cellular phones and other portable electronics.

The device has very low insertion loss in the pass band (to approximately 10MHz) and high attenuation at frequencies ranging from 800MHz to 3GHz. Each line features two stages of TVS diode protection. The TVS diodes provide effective suppression of ESD voltages in excess of 15kV (air discharge) and 8kV (contact discharge) per IEC 61000-4-2, level 4. The TVS diodes are bidirectional for supporting bipolar audio signals without distortion.

The SFC2280-10 is a 6-bump, 0.5mm pitch flip chip array with a 3x2 bump grid. It measures 1.5 x 1.0 x 0.65mm. This small outline makes the device especially well suited for portable applications. The flip chip design results in lower inductance for optimized filter and ESD clamping performance.

Features

- ◆ Flip Chip bidirectional EMI/RFI filter with integrated ESD protection
- ◆ ESD protection to **IEC 61000-4-2 (ESD) Level4, +/-15kV (air), +/-8kV (contact)**
- ◆ Filter performance: 20dB attenuation at 800MHz
- ◆ Small chip scale package requires less board space
- ◆ Low profile (< 0.65mm)
- ◆ Bidirectional TVS to support negative voltages in audio applications
- ◆ Maximum Dimensions: 1.5 x 1.0 x 0.65 mm
- ◆ TVS Working voltage: 5V
- ◆ Series Resistor: 10Ω
- ◆ Solid-state technology

Mechanical Characteristics

- ◆ JEDEC MO-211, Variation BB, 0.50 mm Pitch Chip Scale Package (CSP)
- ◆ Marking : Marking Code + Chevron
- ◆ Packaging : Tape and Reel

Applications

- ◆ Cell Phone Handsets and Accessories
- ◆ Personal Digital Assistants (PDA's)
- ◆ Notebook & Hand Held Computers
- ◆ Digital Camcorders
- ◆ Pagers
- ◆ MP3 Players

Circuit Diagram (Each Line)

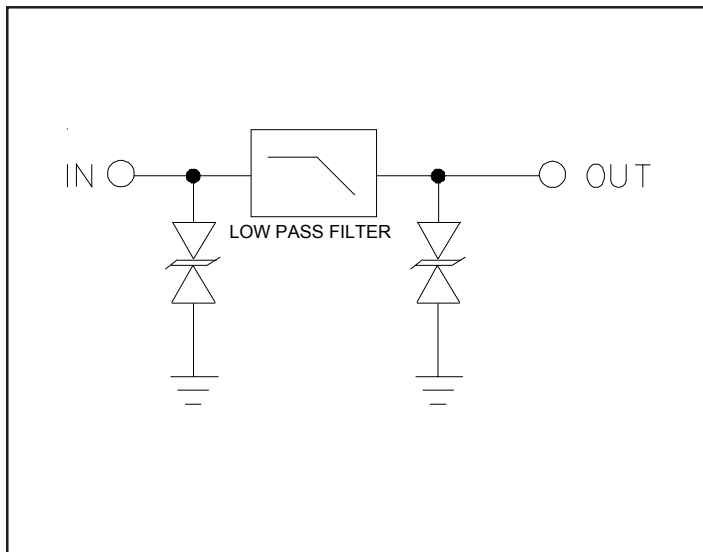

Schematic & PIN Configuration

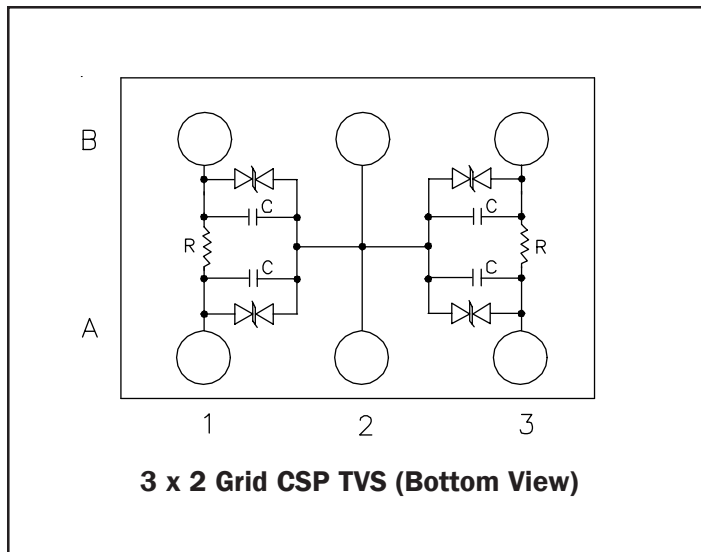

PROTECTION PRODUCTS
PRELIMINARY
Absolute Maximum Rating

Rating	Symbol	Value	Units
Steady-State Power	P_{SS}	100	mW
ESD per IEC 61000-4-2 (Air) ESD per IEC 61000-4-2 (Contact)	V_{ESD}	>16 >10	kV
Soldering Temperature	T_L	260 (10 seconds)	°C
Operating Temperature	T_J	-55 to +125	°C
Storage Temperature	T_{STG}	-55 to +150	°C

Electrical Characteristics (T=25°C)

SFC2280-10						
Parameter	Symbol	Conditions	Minimum	Typical	Maximum	Units
TVS Reverse Stand-Off Voltage	V_{RWM}				5	V
TVS Reverse Breakdown Voltage	V_{BR}	$I_t = 1\text{mA}$	6			V
TVS Reverse Leakage Current	I_R	$V_{RWM} = 5\text{V}, T=25^\circ\text{C}$			5	μA
Resistor Temperature Coefficient	T_{COEFF}	Each Line			400	ppm
Series Resistance	R	Each Line	9	10	11	Ω
TVS Capacitance	C_{TVS}	Each Individual TVS $V_R = 0\text{V}, f = 1\text{MHz}$		30		pF
Total Capacitance	C_{TOT}	Any I/O to Ground $V_R = 0\text{V}, f = 1\text{MHz}$		160		pF

Typical Characteristics (continued)

Typical Insertion loss (A1-B1 to Gnd)

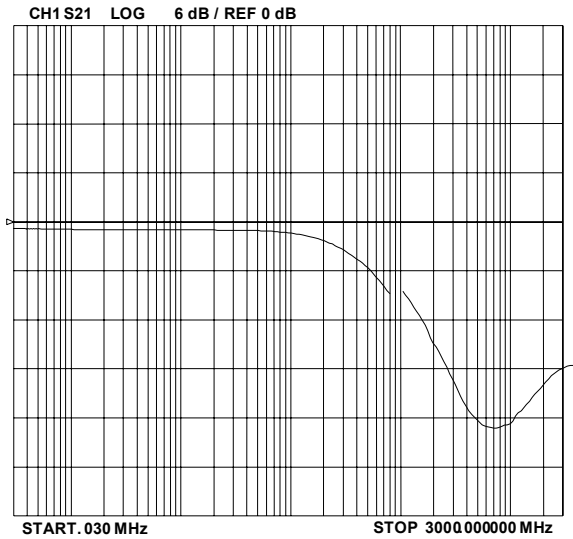

Typical Insertion loss (A3-B3 to Gnd)



Clamping Voltage vs. Peak Pulse Current

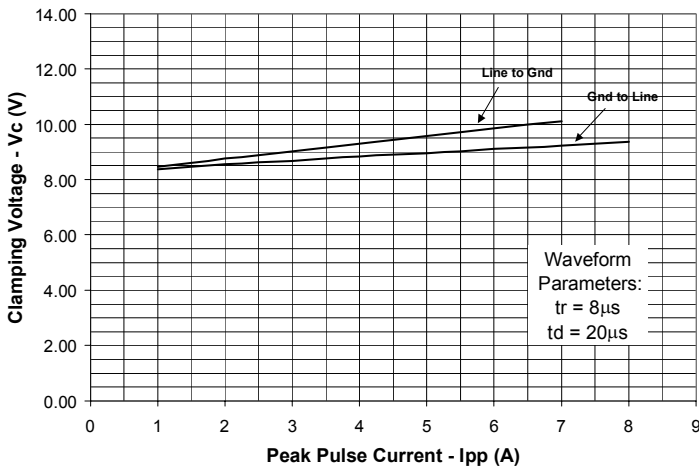

Analog Crosstalk (B1 to A3)



ESD Clamping (8kV Contact)

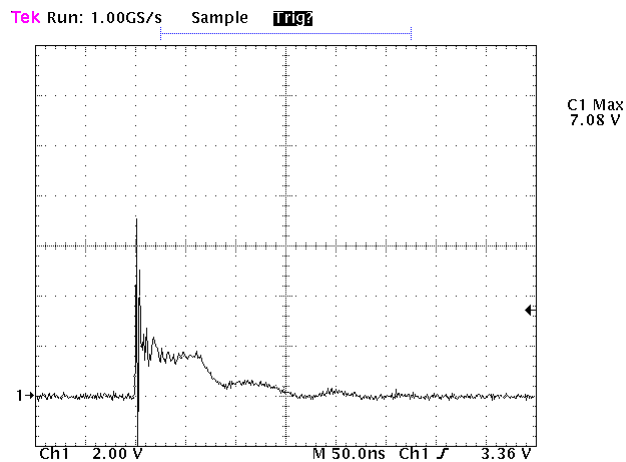

ESD Clamping (15kV Air)

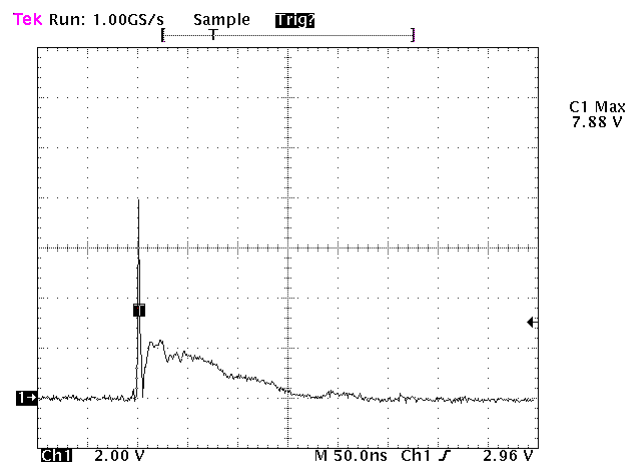

Applications Information
Device Connection Options

The SFC2280-10 has solder bumps located in a 3 x 2 matrix layout on the active side of the device. The bumps are designated by the numbers 1 - 3 along the horizontal axis and letters A - B along the vertical axis. The lines to be protected are connected at bumps A1, B1, A3, and B3. Bumps A2 & B2 are connected to ground. All path lengths should be kept as short as possible to minimize the effects of parasitic inductance in the board traces.

Wafer Level CSP TVS

CSP TVS devices are wafer level chip scale packages. They eliminate external plastic packages and leads and thus result in a significant board space savings. Manufacturing costs are minimized since they do not require an intermediate level interconnect or interposer layer for reliable operation. They are compatible with current pick and place equipment further reducing manufacturing costs. Certain precautions and design considerations have to be observed however for maximum solder joint reliability. These include solder pad definition, board finish and assembly parameters.

Printed Circuit Board Mounting

Non-solder mask defined (NSMD) land patterns are recommended for mounting the SFC2280-10. Solder mask defined (SMD) pads produce stress points near the solder mask on the PCB side that can result in solder joint cracking when exposed to extreme fatigue conditions. The recommended pad size is 0.225 ± 0.010 mm with a solder mask opening of 0.350 ± 0.025 mm.

Grid Courtyard

The recommended grid placement courtyard is 1.3 x 1.8 mm. The grid courtyard is intended to encompass the land pattern and the component body that is centered in the land pattern. When placing parts on a PCB, the highest recommended density is when one courtyard touches another.

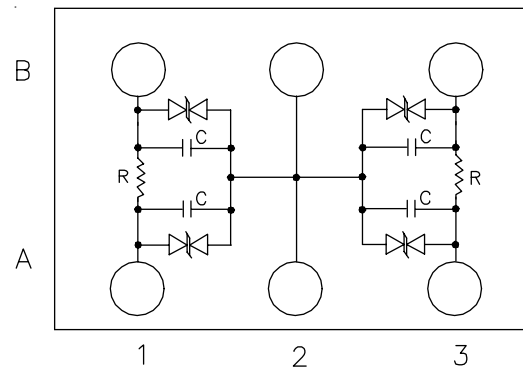
Pin Identification and Configuration (Bottom View)

Pin	Identification
A1	Line 1 In (From Speaker)
B1	Line 1 Out (To Audio Circuit)
A3	Line 2 In (From Speaker)
B3	Line 2 Out (To Audio Circuit)
A2	Ground
B2	Ground

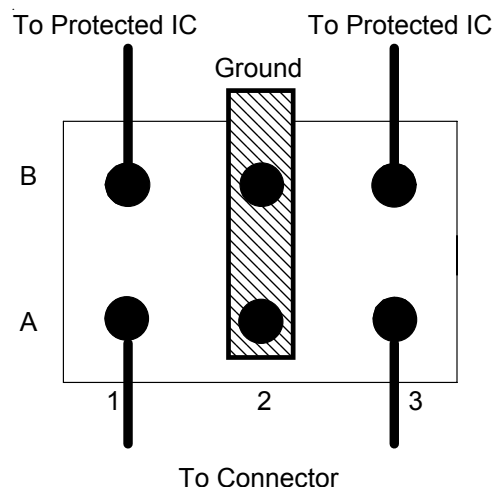
Layout Example

Applications Information (Continued)

Printed Circuit Board Finish

A uniform board finish is critical for good assembly yield. Two finishes that provide uniform surface coatings are immersion nickel gold and organic surface protectant (OSP). A non-uniform finish such as hot air solder leveling (HASL) can lead to mounting problems and should be avoided.

Stencil Design

A properly designed stencil is key to achieving adequate solder volume without compromising assembly yields. A 0.100mm thick, laser cut, electro-polished stencil with 0.275mm square apertures and rounded corners is recommended.

Reflow Profile

The flip chip TVS can be assembled using standard SMT reflow processes. As with any component, thermal profiles at specific board locations can vary & must be determined by the manufacturer. The flip chip TVS peak reflow temperature is 230 ± 10 °C, but the device can withstand up to 260 °C peak reflow temperature. Time above eutectic temperature (183 °C) should be 50 ± 10 seconds. During reflow, the component self-aligns itself on the pad.

Circuit Board Layout Recommendations for Suppression of ESD

Good circuit board layout is critical for the suppression of ESD induced transients. The following guidelines are recommended:

- Place the TVS near the input terminals or connectors to restrict transient coupling.
- Minimize the path length between the TVS and the protected line.
- Minimize all conductive loops including power and ground loops.
- The ESD transient return path to ground should be kept as short as possible.
- Never run critical signals near board edges.
- Use ground planes whenever possible.

NSMD Package Footprint

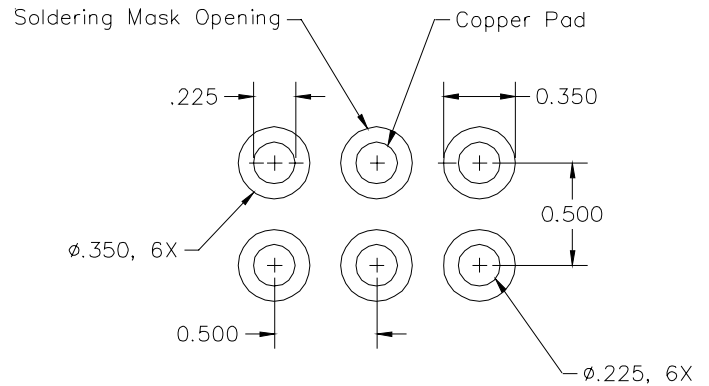

Stencil Design

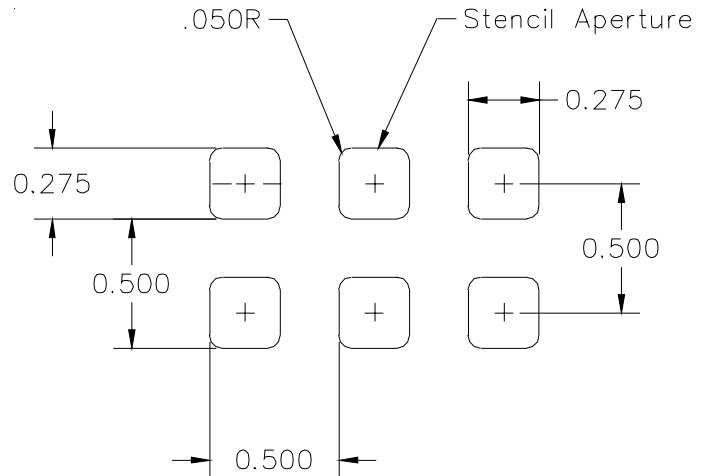

Insertion Loss

The insertion loss of the device is the ratio of the power delivered to the load with and without the filter in the circuit. This parameter is dependent upon the impedance of the source and the load. The standard impedance of test equipment that is used to measure filter frequency response is 50Ω . In order to obtain an accurate measurement of the filter performance, an evaluation board with 50Ω transmission lines is used. The evaluation board for the SFC2280-10 is shown in Figure 1. The board is specifically designed for frequency response analysis. The evaluation board contains SMA connectors at each of the circuits inputs and outputs. The connections are made with 50Ω traces. An HP 8753E network analyzer with an internal spectrum analyzer and tracking generator is used. This equipment has the capability to sweep the device from 3kHz to 3GHz. The analyzer's source (R_s) impedance is equal to the load (R_L) impedance which is equal to 50Ω .

Pins A1, A3, B1, and B3 of the device are connected to SMA connectors via the 50 ohm traces. Pins A1 and A3 are the data line inputs and pins B1 and B3 are the outputs. Pin A2 is connected to the test point marked VCC. Pin B2 is connected to GND. Since pin A2 and B2 are connected internally within the device, a VCC connection is not necessary.

A typical insertion loss characteristic is shown in Figure 2. As shown, the device has very low insertion loss in the pass band (to approximately 10MHz) and good attenuation at high frequencies (approximately 100MHz to 3GHz).

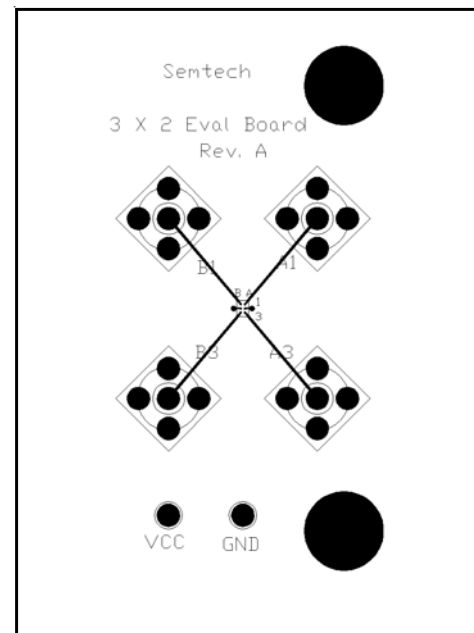

Figure 1 - SFC2280-10 Evaluation Board

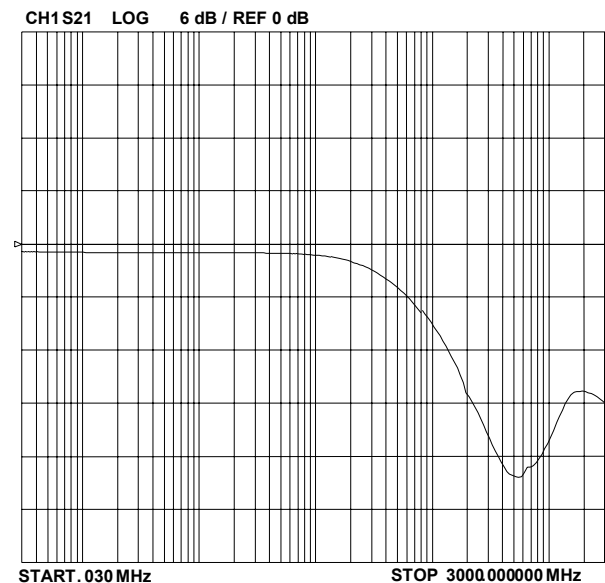

Figure 2 - Typical Insertion Loss S21

Applications Information (Continued)

Voltage Clamping Characteristics.

The clamping characteristics of the SFC2280-10 are optimized by the use of two TVS diodes in the protection circuit (Figure 3). An ESD strike on the protected line will be initially suppressed by the first TVS diode. The voltage across the TVS will be the clamping voltage of the device (V_{C1}) given by:

$$V_{C1} = V_{br} + R_D * I_{PP}$$

where

V_{br} = Breakdown voltage of the TVS

R_D = Dynamic resistance of the TVS

I_{PP} = Peak pulse (ESD) current

The dynamic resistance of the TVS is very small, typically $< 0.5\Omega$.

The second TVS will be subjected to V_{C1} through the voltage divider formed by the series resistor (R) and the dynamic resistance of the TVS. Since $R \gg R_D$ then by the voltage divider theorem, the voltage seen by the protected IC will be a few millivolts above the breakdown voltage (V_{br}) of the second TVS.

Figure 3 - Clamping Characteristic Model

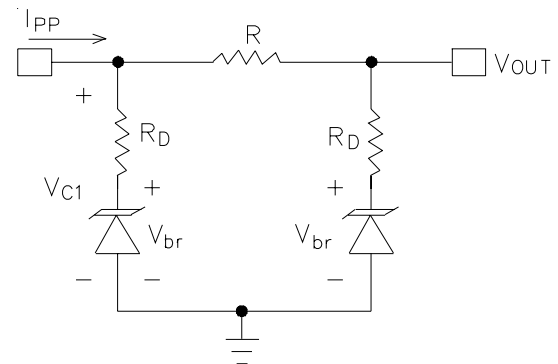

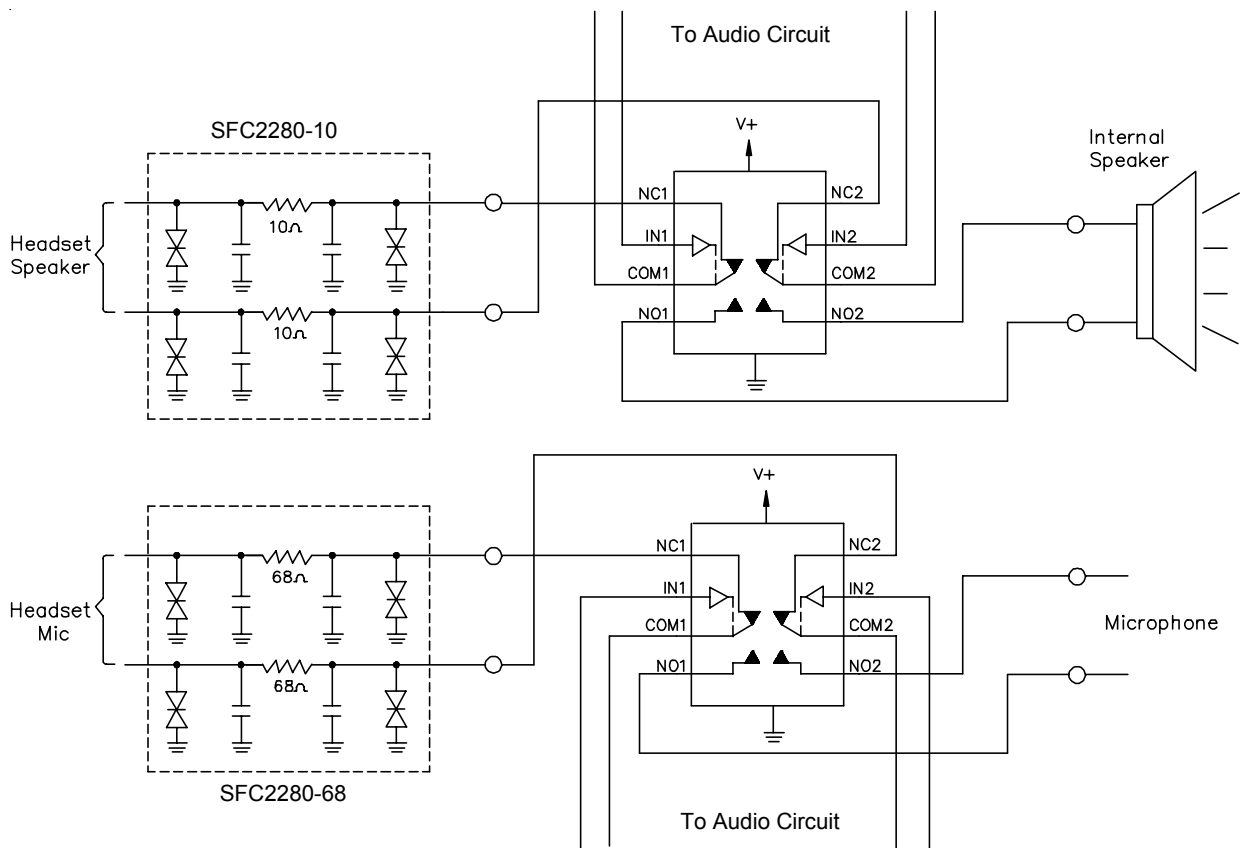
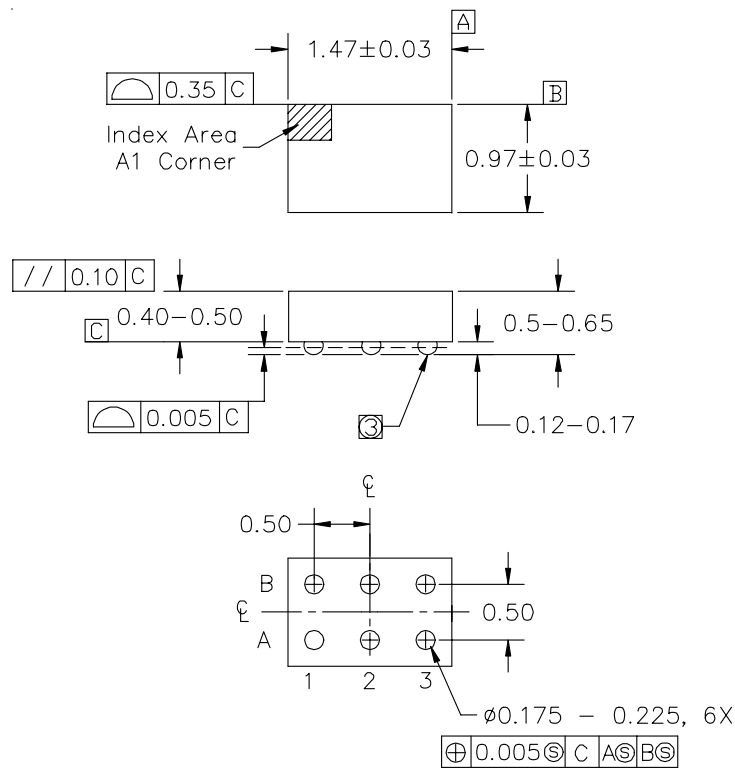
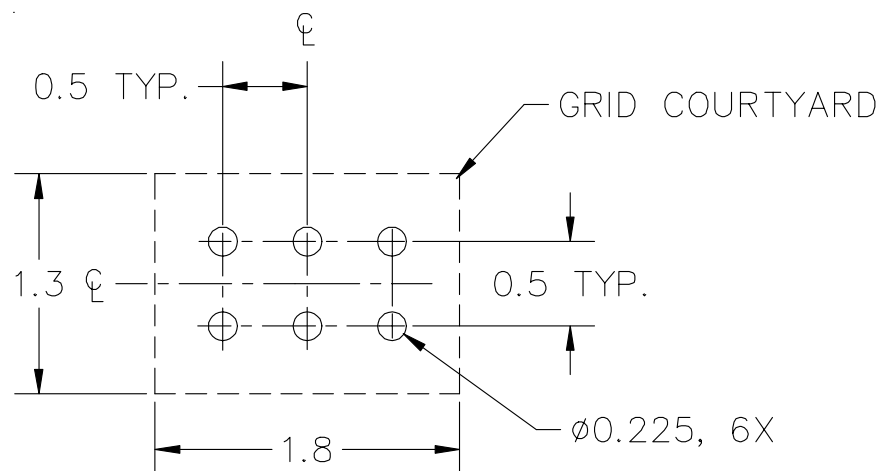

Figure 4 - Cell Phone Headset Audio Port Protection

Outline Drawing

- ① Dimensions in millimeters.
- ② Reference Jedec Registration MO-211, Variation BB.
- ③ 63Sn/Pb Eutectic Bump

Land Pattern

- 1. Dimensions in millimeters.

Marking Codes

Part Number	Marking Code
SFC2280-10	2281

Ordering Information

Part Number	Working Voltage	Qty per Reel	Reel Size
SFC2280-10.TM	5V	6,000	7 Inch

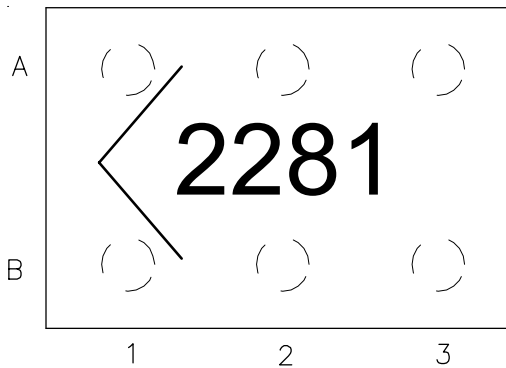

3 x 2 Grid Flip Chip TVS (Top View)

Tape and Reel Specification

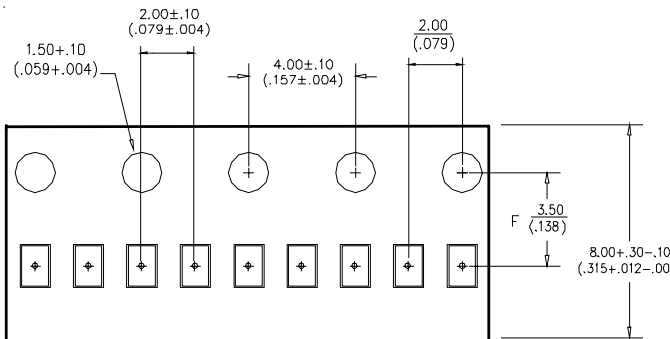

Tape Specifications

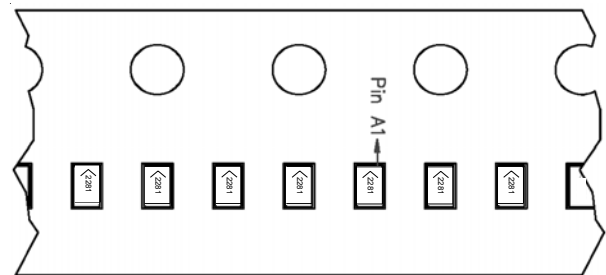

Device Orientation in Tape

Contact Information

Semtech Corporation
 Protection Products Division
 200 Flynn Rd., Camarillo, CA 93012
 Phone: (805)498-2111 FAX (805)498-3804