

Features

- Micro power design
- 2.4 V to 5.5 V battery operation
- High sensitivity and high stability of the magnetic switching points
- High resistance to mechanical stress
- Digital output signal
- Switching for both poles of a magnet (omnipolar)
- Programming pin for the switching direction of the output
- Not suitable for automotive application

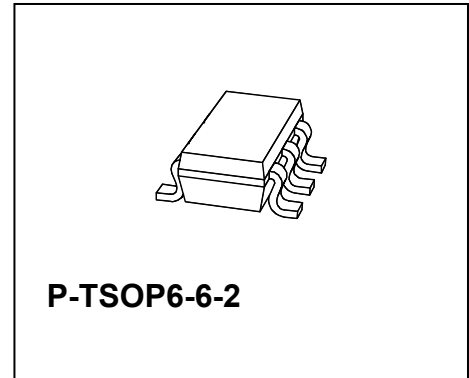

Functional Description

The TLE 4917 is an Integrated Hall-Effect Sensor designed specifically to meet the requirements of low-power devices. e.g. as an On/Off switch in Cellular Flip-Phones, with battery operating voltages of 2.4V – 5.5V.

Precise magnetic switching points and high temperature stability are achieved through the unique design of the internal circuit.

An onboard clock scheme is used to reduce the average operating current of the IC.

During the operate phase the IC compares the actual magnetic field detected with the internally compensated switching points. The output Q is switched at the end of each operating phase.

During the Stand-by phase the output stage is latched and the current consumption of the device reduced to some μA .

The IC switching behaviour is omnipolar, i.e. it can be switched on with either the North or South pole of a magnet.

The PRG pin can be connected to V_S which holds the output V_Q at a High level for $B=0\text{mT}$; conversely the output V_Q can be inverted by connecting the PRG pin to GND, which will hold the output V_Q at a Low level for $B=0\text{mT}$. In this later case the presence of an adequate magnetic field will cause the output V_Q to switch to a High level (i.e. off state).

Type	Marking	Ordering Code	Package
TLE 4917	17s	Q62705K 605	P-TSOP6-6-2

Pin Configuration (top view)

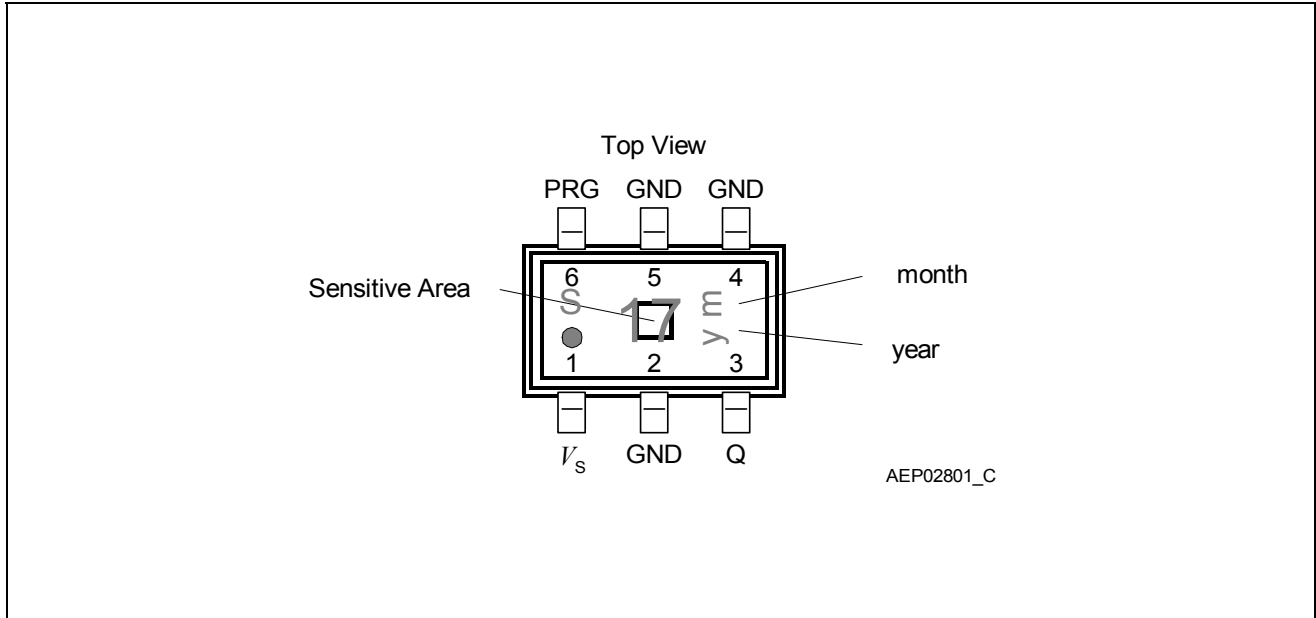

Figure 1

Pin Definitions and Functions

Pin	Symbol	Function
1	V_s	Supply Voltage
2	GND	Ground
3	Q	Open Drain Input
4	GND	Ground
5	GND	Ground
6	PRG	Programming Input

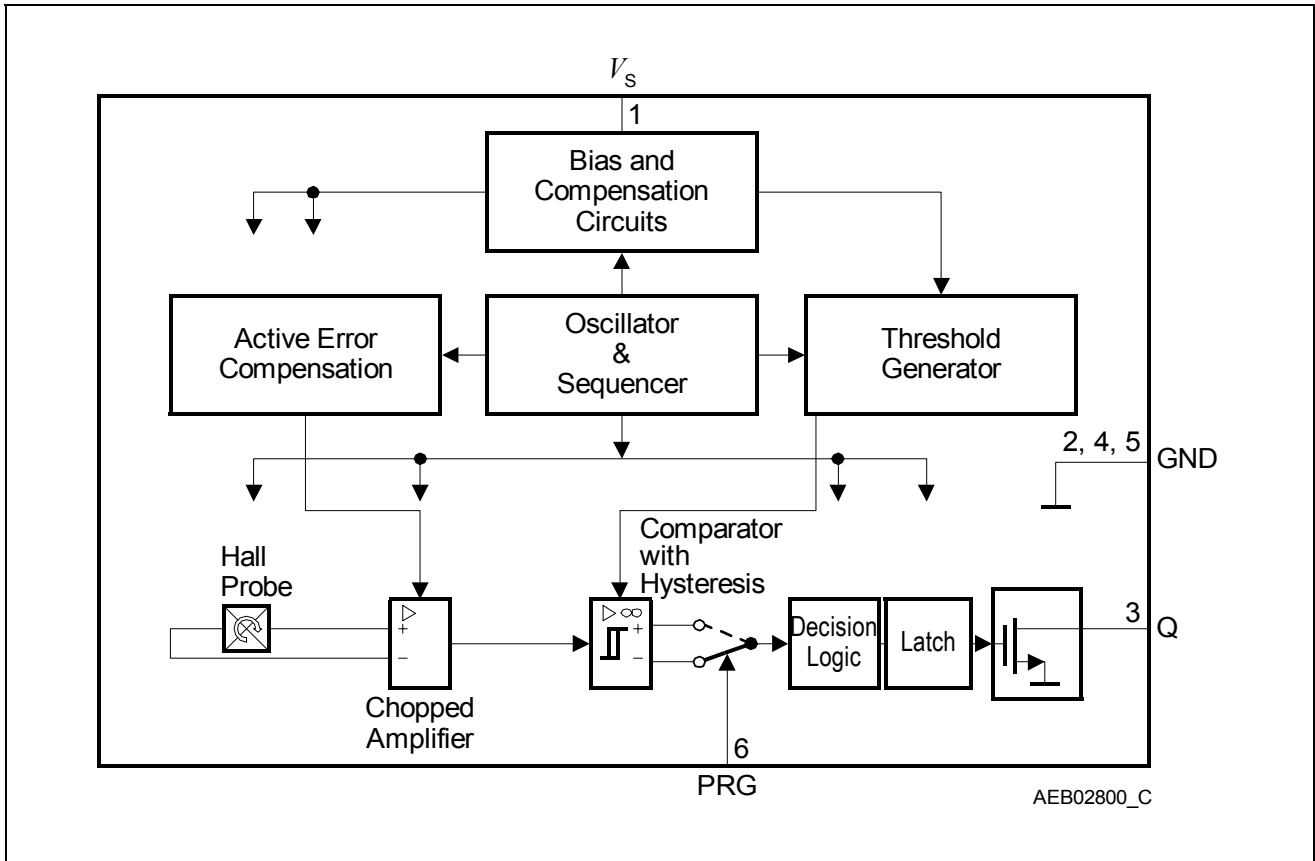

Figure 2 Block Diagram

Circuit Description

The Low Power Hall IC Switch comprises a Hall probe, bias generator, compensation circuits, oscillator, output latch and an n-channel open drain output transistor.

The bias generator provides currents for the Hall probe and the active circuits. Compensation circuits stabilize the temperature behavior and reduce technology variations.

The Active Error Compensation rejects offsets in signal stages and the influence of mechanical stress to the Hall probe caused by molding and soldering processes and other thermal stresses in the package. This chopper technique together with the threshold generator and the comparator ensures high accurate magnetic switching points.

Very low power consumption is achieved with a timing scheme controlled by an oscillator and a sequencer. This circuitry activates the sensor for 50 μ s (typical operating time) sets the output state after sequential questioning of the switch points and latches it with the beginning of the following standby phase (typ. 130 ms). In the standby phase the average current is reduced to typical 3.5 μ A. Because of the long standby time compared to the operating time the overall averaged current is only slightly higher than the standby current.

By connecting the programming pin to GND (normal to V_s) the Output State can be inverted to further reduce the current consumption in applications where a high magnetic field is the

normal state. In that case the output Q is off at high magnetic fields and no current is flowing in the open drain transistor.

The output transistor can sink up to 1 mA with a maximal saturation voltage V_{QSAT} .

Absolute Maximum Ratings

Parameter	Symbol	Limit Values		Unit	Notes
		min.	max.		
Supply Voltage	V_S	- 0.3	5.5	V	
Supply Current	I_S	- 1	2.5	mA	
Output Voltage	V_Q	- 0.3	5.5	V	
Output Current	I_Q	- 1	2	mA	
Programming Pin Voltage	V_{PRG}	- 0.3	5.5 ¹⁾	V	
Junction temperature	T_j	- 40	150	°C	
Storage temperature	T_S	- 40	150	°C	
Magnetic Flux Density	B	-	unlimited	mT	
Thermal Resistance P-TSOP6-6-2	$R_{th JA}$	-	35	K/W	

¹⁾ V_{PRG} must not exceed V_S by more than 0.3V

Note: Stresses above those listed here may cause permanent damage to the device. Exposure to absolute maximum rating conditions for extended periods may affect device reliability.

ESD Protection

Human Body Model (HBM) tests according to:
EOS/ESD Association Standard S5.1-1993 and Mil. Std. 883D method 3015.7

Parameter	Symbol	Limit Values		Unit	Notes
		Min.	max.		
ESD Voltage	V_{ESD}	± 2		kV	$R = 1.5 \text{ k}\Omega$, $C = 100 \text{ pF}$; $T = 25 \text{ }^\circ\text{C}$

Operating Range

Parameter	Symbol	Limit Values			Unit	Notes
		Min.	typ.	max.		
Supply voltage	V_S	2.4	2.7	5.5	V	¹⁾
Output voltage	V_Q	- 0.3	2.7	5.5	V	
Programming Pin Voltage	V_{PRG}	- 0.3	0	0.3	V	Inverted output state
		$V_S - 0.3$	V_S	$V_S + 0.3$		Standard output state
Ambient Temperature	T_A	- 40	25	85	°C	

¹⁾ A Ceramic Bypass Capacitor of 10 nF at V_S to GND is highly recommended.

AC/DC Characteristics

Parameter	Symbol	Limit Values			Unit	Notes
		Min.	typ.	Max.		
Averaged Supply Current	I_{SAVG}	1	4	20	µA	
Averaged Supply Current during Operating Time	I_{SOPAVG}	0.5	1.1	2.5	mA	
Transient Peak Supply Current during Operating Time	I_{SOPT}	-	-	2.5	mA	$t < 100$ ns
Supply Current during Standby Time	I_{SSTB}	1	3.5	20	µA	
Output Saturation Voltage	V_{QSAT}	-	0.13	0.4	V	$I_Q = 1$ mA
Output Leakage Current	I_{QLEAK}	-	0.01	1	µA	
Output Rise Time	t_r	-	0.3	1	µs	$R_L = 2.7$ kΩ; $C_L = 10$ pF
Output Fall Time	t_f	-	0.1	1	µs	$R_L = 2.7$ kΩ; $C_L = 10$ pF
Operating Time	t_{op}	15	50	93 ^{1) 2)}	µs	
Standby Time	t_{stb}	-	130	240 ³⁾	ms	
Duty Cycle	t_{op} / t_{stb}	-	0.039	-	%	
Start-up Time of IC	t_{stu}	-	6	12	µs	⁴⁾

¹⁾ for $V_S=3.5$ V the max. Operating Time $t_{op\ max} = 85$ µs

²⁾ includes the Start-up Time t_{stu}

³⁾ for $V_S=3.5$ V the max. Standby Time $t_{stb\ max} = 220$ ms

⁴⁾ initial power on time. V_S must be applied in this time (typ. 6µs to max. 12µs) to get already a valid output state after the first operating phase (typ. 56µs). For rise times of $V_S > 12$ µs, the output state is valid after the second operating phase (includes one standby phase), e.g. happens only when the battery in flip phones is changed.

Magnetic Characteristics

PRG Pin Connected to V_S

Parameter	Symbol	Limit Values			Unit	Notes
		Min.	typ.	max.		
Operate Points	B _{OPS}	3.5	5	7	mT	1)
	B _{OPN}	-7	-5	-3.5	mT	
Release Points	B _{RPS}	2.2	4	6	mT	1)
	B _{RPN}	-6	-4	-2.2	mT	
Hysteresis	B _{HYS}	0.2	1	2	mT	

¹⁾ Positive magnetic fields are related to the approach of a magnetic south pole to the branded side of package

PRG Pin Connected to GND

Parameter	Symbol	Limit Values			Unit	Notes
		Min.	typ.	max.		
Operate Points	B _{OPS}	2.2	4	6	mT	1)
	B _{OPN}	-6	-4	-2.2	mT	
Release Points	B _{RPS}	3.5	5	7	mT	1)
	B _{RPN}	-7	-5	-3.5	mT	
Hysteresis	B _{HY}	0.2	1	2	mT	

¹⁾ Positive magnetic fields are related to the approach of a magnetic south pole to the branded side of package

Note: The listed AC/DC and magnetic characteristics are ensured over the operating range of the integrated circuit. Typical characteristics specify mean values expected over the production spread. If not other specified, typical characteristics apply at $T_j = 25\text{ °C}$ and $V_S = 2.7\text{ V}$.

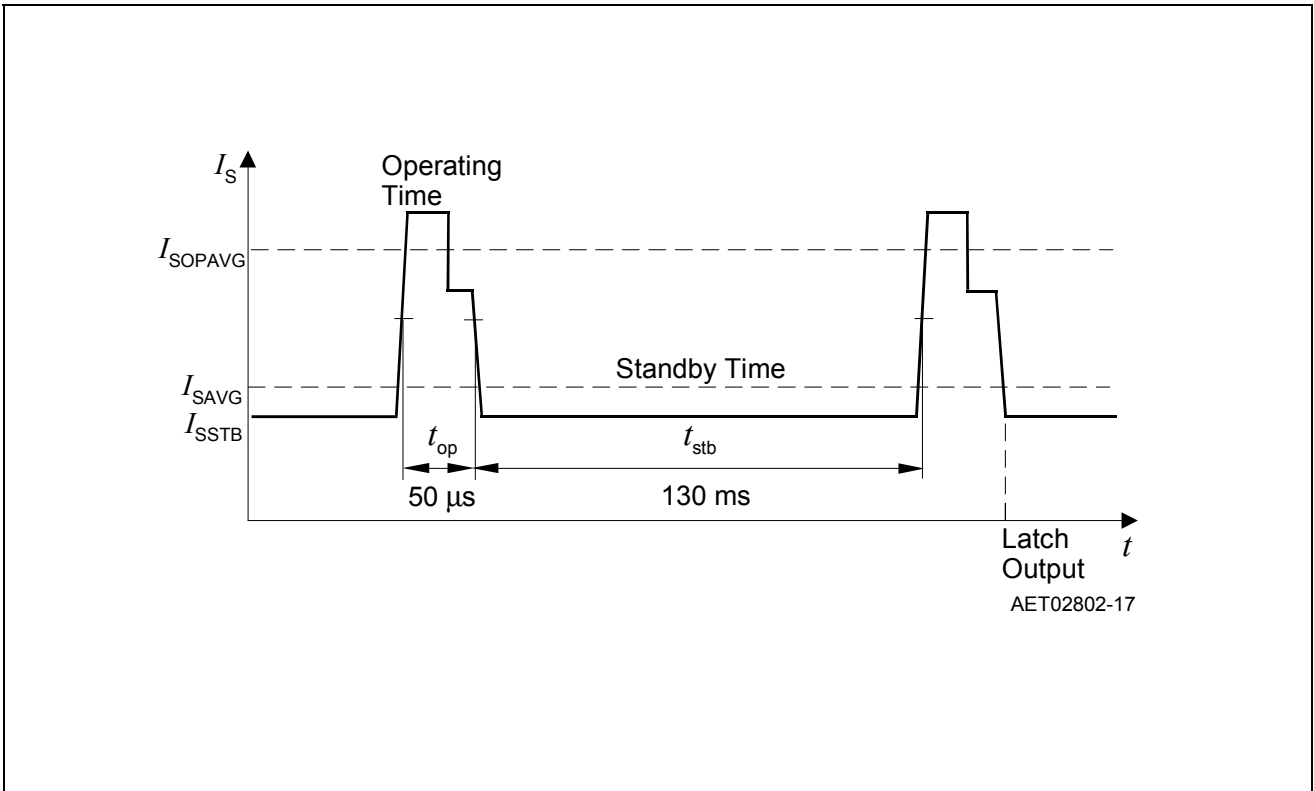

Figure 3 Timing Diagram

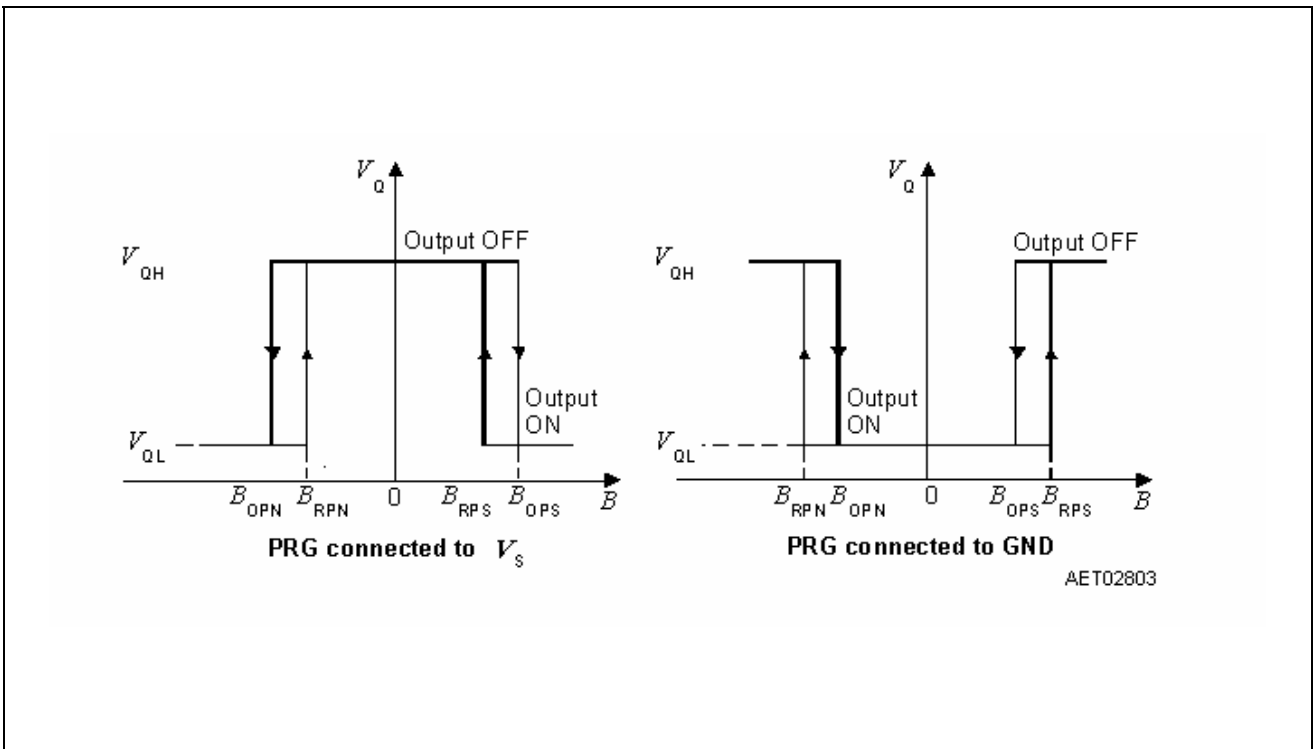
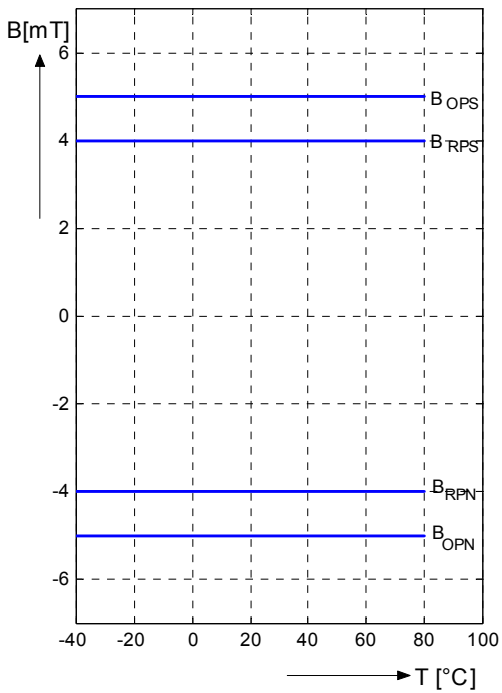

Figure 4 Programming of Output with the PRG Pin

All curves reflect typical values at the given parameters for T_A in $^{\circ}\text{C}$ and V_S in V.

Magnetic Switching Points versus Temperature ($V_S=2.7\text{V}$) (PRG Pin Connected to V_S)



Magnetic Switching Points versus Supply Voltage V_S ($T_A=20^{\circ}\text{C}$) (PRG Pin Connected to V_S)

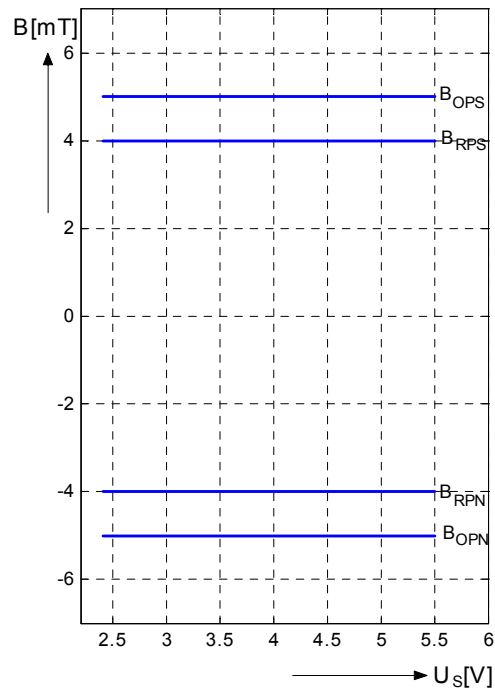

Supply current I_{SOPAVG} during Operating Time versus Temperature ($V_S=2.7\text{V}$)

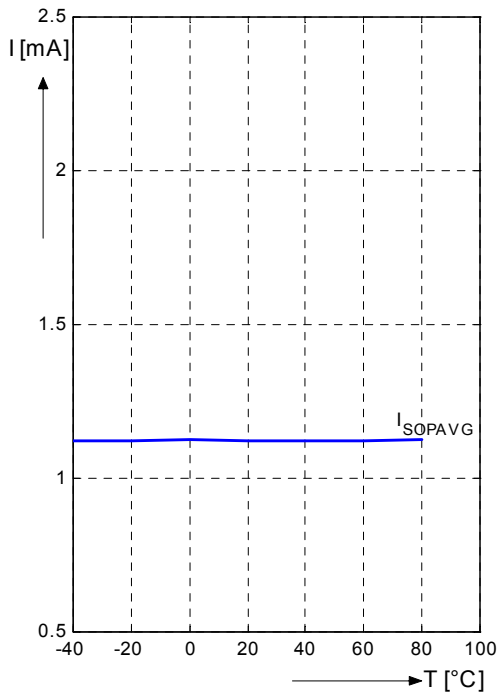

Supply current I_{SOPAVG} during Operating Time versus Supply Voltage V_S ($T_A=20^{\circ}\text{C}$)

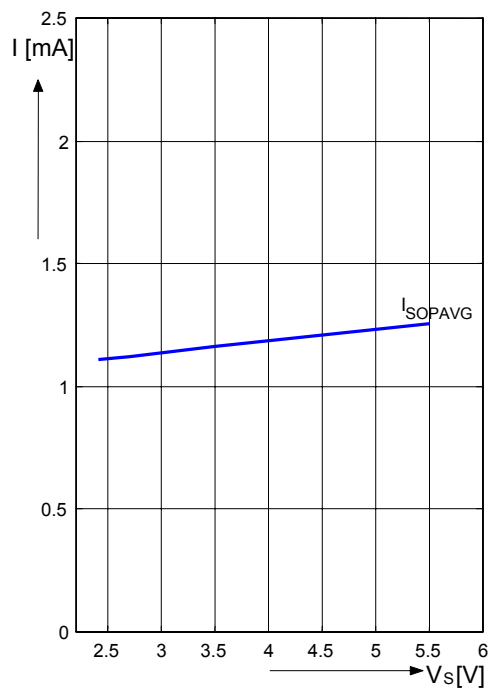

**Supply current I_{SSTB} during Standby
Time versus Temperature ($V_S=2.7V$)**

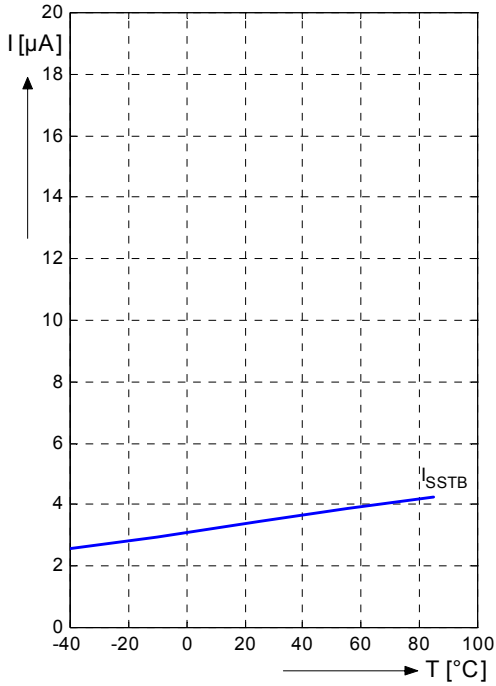

**Supply current I_{SSTB} during Standby
Time versus Supply Voltage V_S ($T_A=20^\circ C$)**

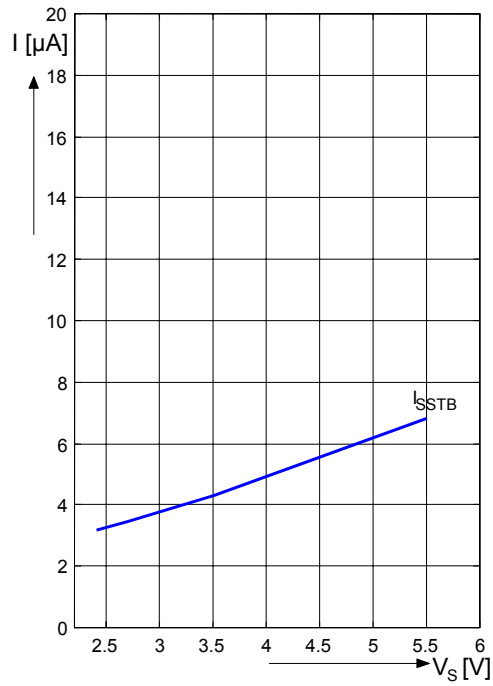

**Output Saturation voltage V_{QSAT}
versus Temperature ($I_Q=1mA$)**

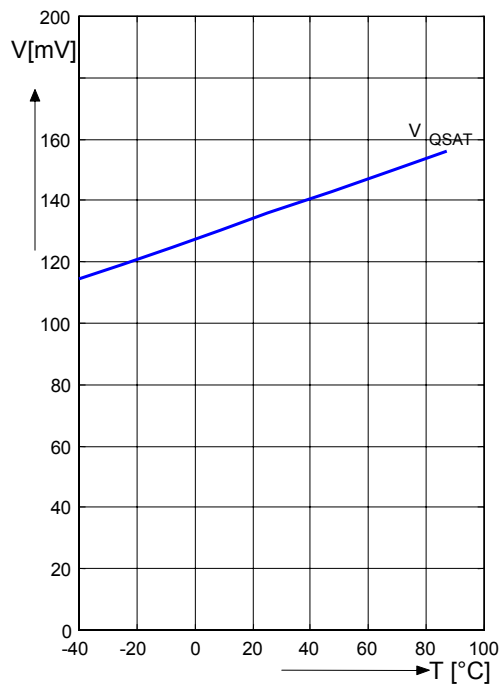

**Standby Time t_{stb} versus Temperature
($V_S = 2.7V$)**

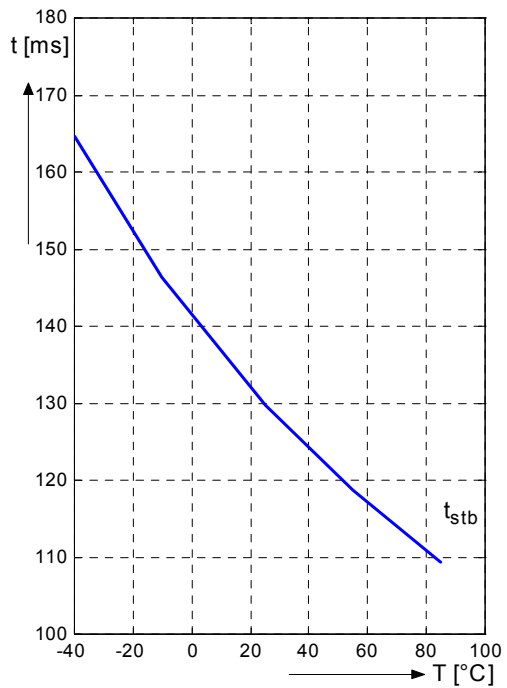

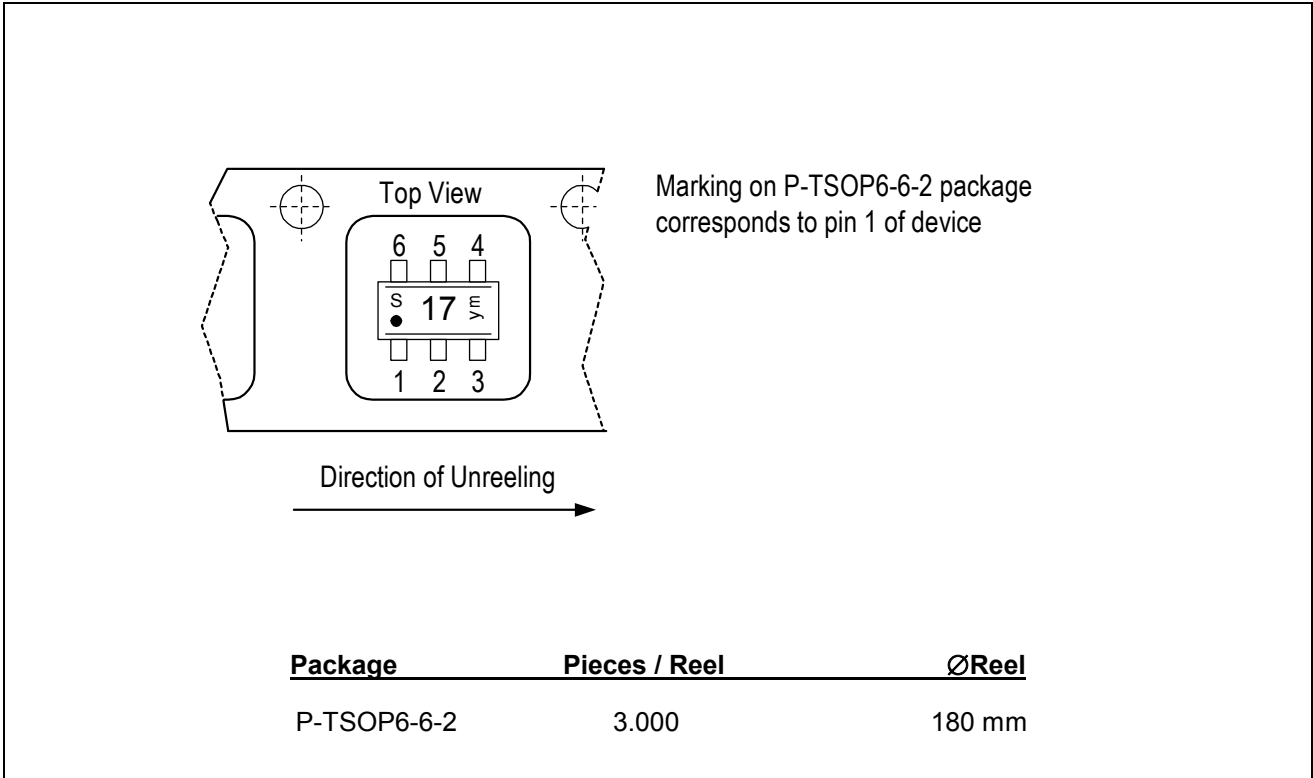

Figure 5 Marking and Tape Loading Orientation

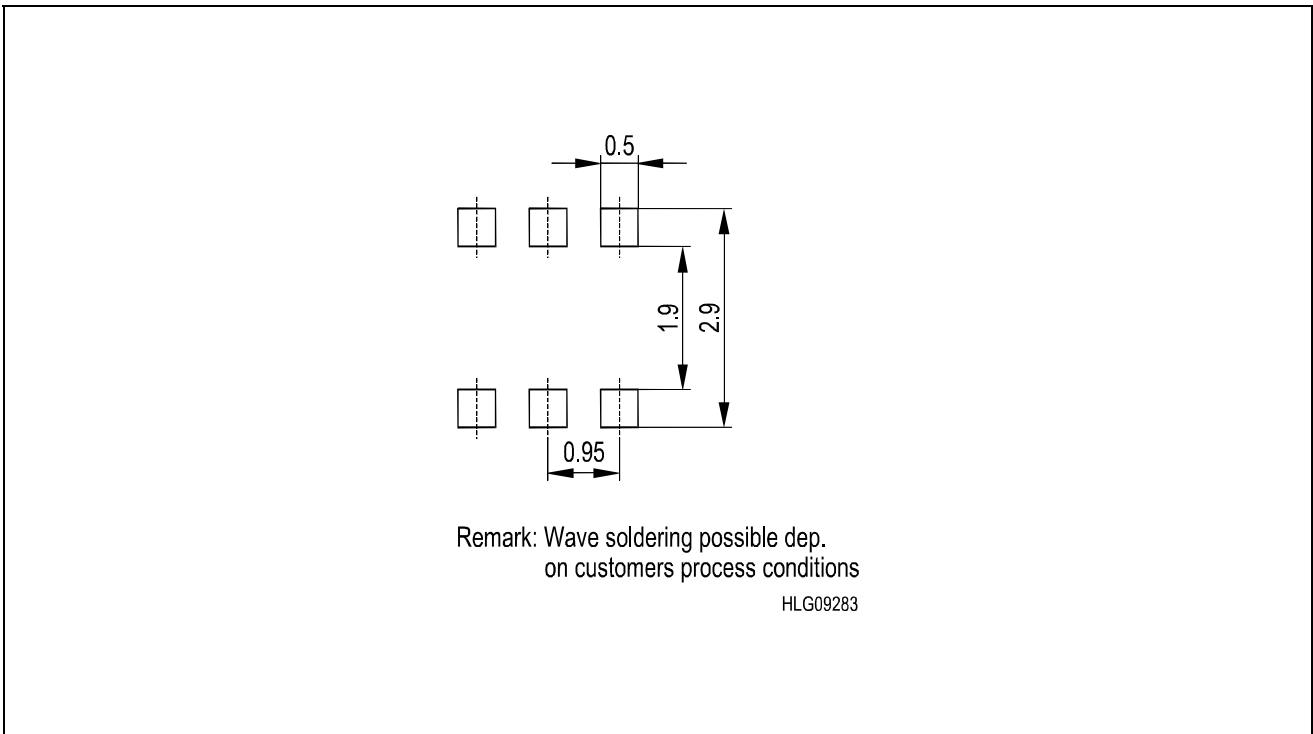
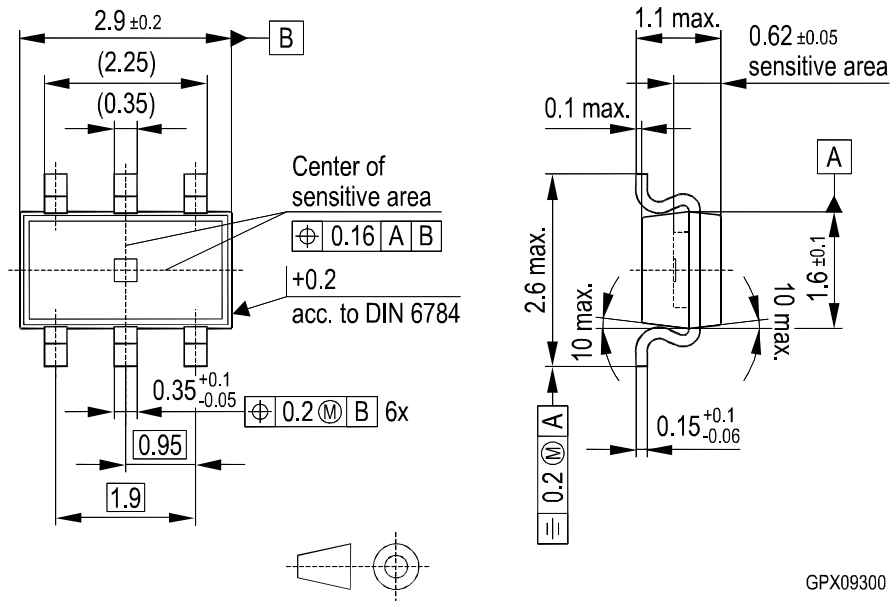

Figure 6 Foot Print Reflow Soldering

Package Dimensions

P-TSOP6-6-2 (Plastic Thin Small Outline-Package)



weight : 0.015g
coplanary : 0.1mm

Sorts of Packing

Package outlines for tubes, trays etc. are contained in our Data Book "Package Information".

SMD = Surface Mounted Device

Dimensions in mm

Information about the application circuit of the TLE 4917

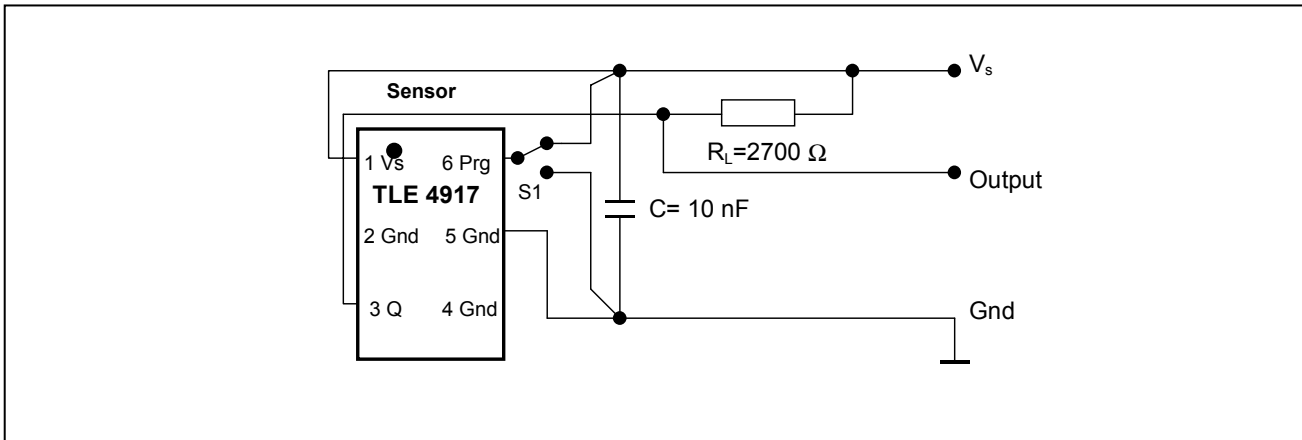

Application circuit TLE 4917

The minimum value for the pull up resistor can be calculated with the power supply voltage V_s , the maximum current $I_{Q_{max}}$ and the minimum output saturation voltage V_{QSAT} .

Example:

for $V_s = 3\text{ V}$: $R_{L_{min}} = (V_s - V_{QSAT_{min}})/I_{Q_{max}} = (3\text{ V} - 0,1\text{ V})/0,002\text{ A} = 1435\ \Omega$

Larger values for R_L will reduce the current I_Q and therefore the power consumption. If the resistor R_L is very large ($>100\text{ k}\Omega$) a capacitor (app. 10 pF) between Output and GND pin could be useful if capacitive coupled noise occurs.

The load at the output Q should have a large input resistance to reduce the current through R_L and the power consumption.

The TLE 4917 has 3 ground pins. From a mechanical point of view all ground pins should be connected to ground. Shortest wires should be used to avoid ground loops.

If there is a need to reduce the number of used ground-pins any ground-pin combination may be used. Furthermore it is possible using only one ground-pin at the application, all pins are equivalent.

The capacitor C is highly recommended to reduce noise on the power supply voltage and it will improve the EMI/EMC performance.

Furthermore it decreases the transient peak supply current during operation time. The IC toggles between low and high current consumption. This behaviour might produce additional noise at the power supply. The capacitor will reduce this noise.

Furthermore this capacitor is used to supply the sensor if microbreaks (short loss of supply voltage) occur.

Shortest connection wires between IC and capacitor should be used to avoid noise.

The switch S1 shows the programming feature of the output.

Example:

If the PRG-pin is connected to V_s the IC will hold the output Q at a high voltage level for $B = 0\text{ mT}$ in this circuit. A magnetic field larger than the operating point will switch the output to low level. In typical applications the PRG-pin is connected directly to V_s or to GND depending on the technical needs. Avoid using a floating PRG-pin.



TLE 4917	
Revision History: 2002-08-22	
Previous Version:	
Page	Subjects (major changes since last revision)

For questions on technology, delivery and prices please contact the Infineon Technologies Offices in Germany or the Infineon Technologies Companies and Representatives worldwide: see our webpage at <http://www.infineon.com>

We Listen to Your Comments

Any information within this document that you feel is wrong, unclear or missing at all? Your feedback will help us to continuously improve the quality of this document.

Please send your proposal (including a reference to this document) to:

feedback.sensors@infineon.com

Edition 2002-08-22

Published by Infineon Technologies AG

St.-Martin-Strasse 53

D-81541 München

© Infineon Technologies AG 2000

All Rights Reserved.

Attention please!

The information herein is given to describe certain components and shall not be considered as warranted characteristics.

Terms of delivery and rights to technical change reserved.

We hereby disclaim any and all warranties, including but not limited to warranties of non-infringement, regarding circuits, descriptions and charts stated herein.

Infineon Technologies is an approved CECC manufacturer.

Information

For further information on technology, delivery terms and conditions and prices please contact your nearest Infineon Technologies Office in Germany or our Infineon Technologies Representatives worldwide (see address list).

Warnings

Due to technical requirements components may contain dangerous substances. For information on the types in question please contact your nearest Infineon Technologies Office.

Infineon Technologies Components may only be used in life-support devices or systems with the express written approval of Infineon Technologies, if a failure of such components can reasonably be expected to cause the failure of that life-support device or system, or to affect the safety or effectiveness of that device or system. Life support devices or systems are intended to be implanted in the human body, or to support and/or maintain and sustain and/or protect human life. If they fail, it is reasonable to assume that the health of the user or other persons may be endangered.