

# XC6108 Series



Voltage Detector with Separated Sense Pin & Delay Type Capacitor

- ◆ CMOS
- ◆ Highly Accurate :  $\pm 2\%$
- ◆ Ultra Low Power Consumption :  $0.8\mu\text{A(TYP.)}$   
( $V_{IN} = 2.0\text{V}$ )
- ◆ Separated Sense Pin
- ◆ Built-In Delay Circuit, Delay Pin Available

## ■ GENERAL DESCRIPTION

The XC6108 series is highly precise, low power consumption voltage detector, manufactured using CMOS and laser trimming technologies.

Since the sense pin is separated from power supply, it allows the IC to monitor added power supply.

Using the IC with the sense pin separated from power supply enables output to maintain the state of detection even when voltage of the monitored power supply drops to 0V.

Moreover, with the built-in delay circuit, connecting the delay capacitance pin to the capacitor enables the IC to provide an arbitrary release delay time.

Both CMOS and N-channel open drain output configurations are available.

## ■ TYPICAL APPLICATION CIRCUIT

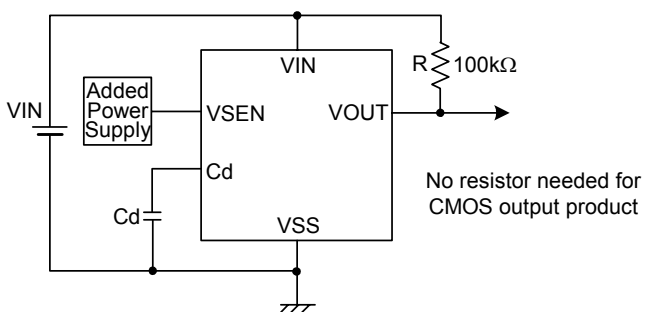

## ■ APPLICATIONS

- Microprocessor reset circuitry
- Charge voltage monitors
- Memory battery back-up switch circuits
- Power failure detection circuits

## ■ FEATURES

- Highly Accurate** :  $\pm 2\%$  (Setting Detect Voltage  $\geq 1.5\text{V}$ )  
:  $\pm 30\text{mV}$  (Setting Detect Voltage  $< 1.5\text{V}$ )
- Ultra Low Power Consumption** :  $0.8\mu\text{A (TYP.)}$  ( $V_{IN} = 2.0\text{V}$ )
- Detect Voltage Range** :  $0.8\text{V} \sim 5.0\text{V}$  in  $100\text{mV}$  increments
- Operating Voltage Range** :  $1.0\text{V} \sim 6.0\text{V}$
- Detect Voltage Temperature Characteristics** :  $\pm 100\text{ppm}/^\circ\text{C(TYP.)}$
- Output Configuration** : CMOS or N-channel open drain
- Operating Temperature Range** :  $-40^\circ\text{C} \sim +85^\circ\text{C}$
- Ultra Small Package** : USP-4  
SOT-25

## ■ TYPICAL PERFORMANCE CHARACTERISTICS

- Output Voltage vs. Sense Voltage

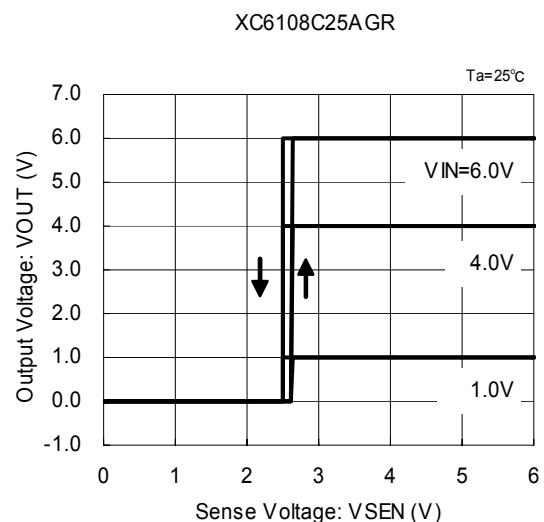

# XC6108 Series

## ■ PIN CONFIGURATION

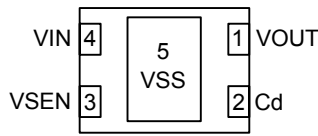

USP-4  
(BOTTOM VIEW)

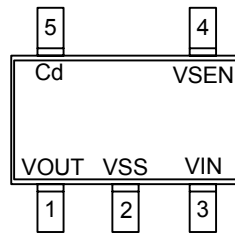

SOT-25  
(TOP VIEW)

\* In the XC6108xxxA/B series, the dissipation pad should not be short-circuited with other pins.

\* In the XC6108xxxC/D series, when the dissipation pad is short-circuited with other pins, connect it to the NC pin (pin No.2) before use.

## ■ PIN ASSIGNMENT

PIN NUMBER		PIN NAME	FUNCTION
USP-4	SOT-25		
1	1	VOUT	Output (Detect "L")
2	5	Cd	Delay Capacitance (*1)
2	-	NC	No Connection
3	4	VSEN	Sense
4	3	VIN	Input
5	2	VSS	Ground (*2)

NOTE:

\*1: With the VSS pin of the USP-4 package, a tab on the backside is used as the pin No.5.

\*2: In the case of selecting no built-in delay pin type, the Cd pin will be used as the N.C.

## ■ PRODUCT CLASSIFICATION

### ● Ordering Information

XC6108 ①②③④⑤⑥

DESIGNATOR	DESCRIPTION	SYMBOL	DESCRIPTION
①	Output Configuration	C	: CMOS output
		N	: N-ch open drain output
② ③	Detect Voltage	08 ~ 50	: e.g. 18→1.8V
④	Output Delay & Hysteresis (Options)	A	: Built-in delay pin, hysteresis 5% (TYP.)
		B	: Built-in delay pin, hysteresis less than 1%
		C	: No built-in delay pin, hysteresis 5% (TYP.)
		D	: No built-in delay pin, hysteresis less than 1%
⑤	Package	G	: USP-4
		M	: SOT-25
⑥	Device Orientation	R	: Embossed tape, standard feed
		L	: Embossed tape, reverse feed

## ■ PACKAGING INFORMATION

### ● USP-4

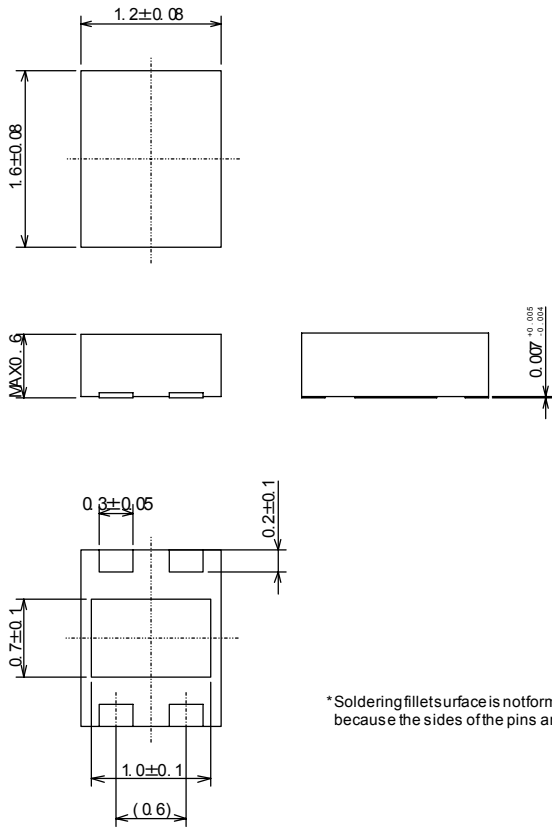

\*Soldering fillets surface is not formed because the sides of the pins are plated.

### ● SOT-25

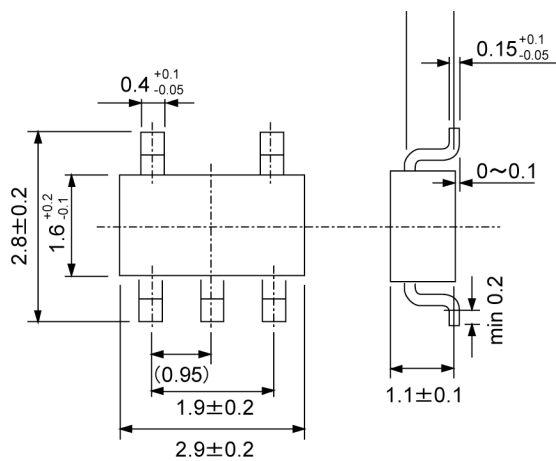

## ■ BLOCK DIAGRAMS

### ● XC6108CxxA/B

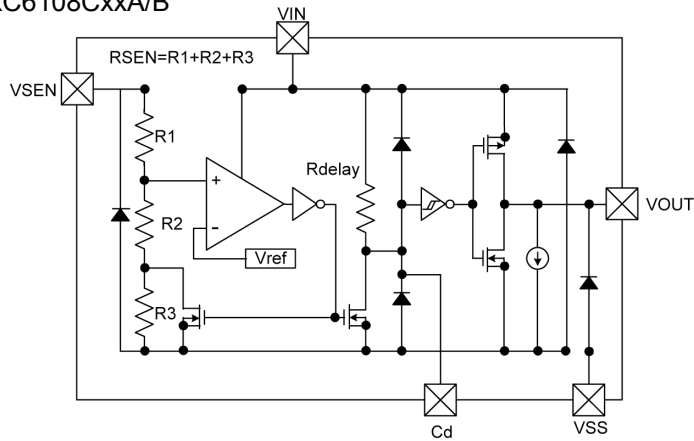

### ● XC6108CxxC/D

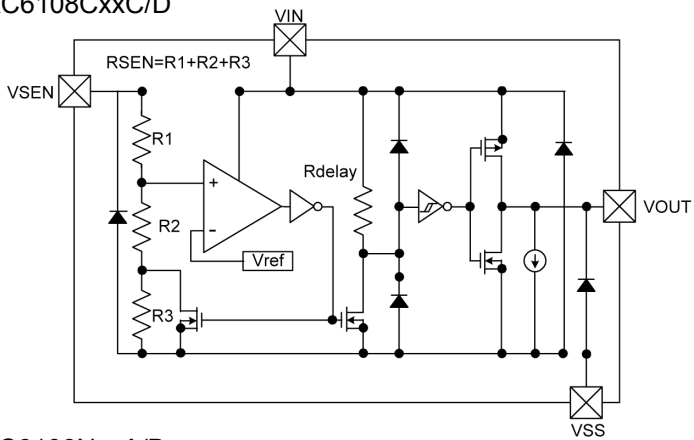

### ● XC6108NxxA/B

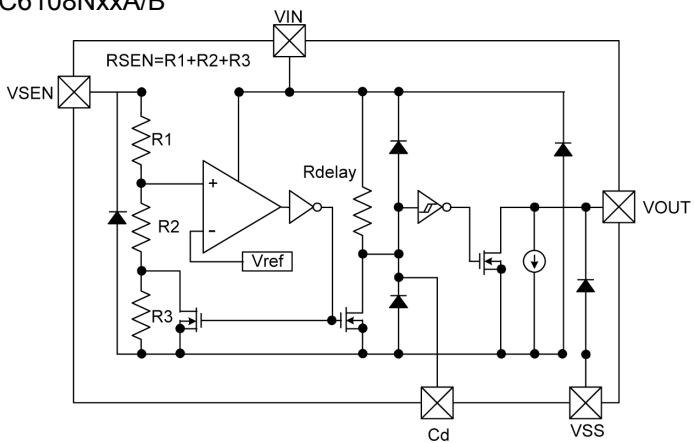

### ● XC6108NxxC/D

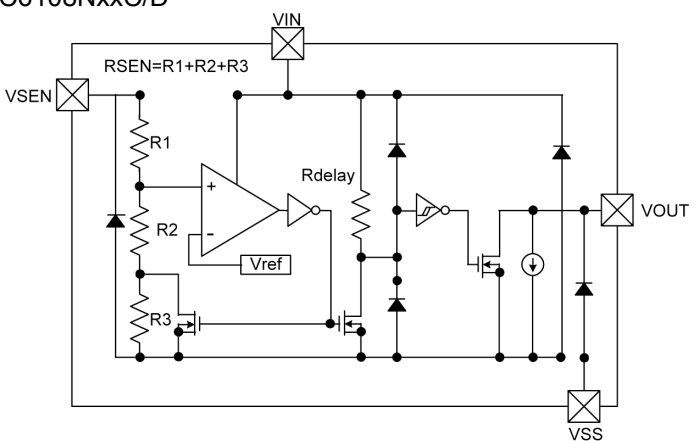

## ■ ABSOLUTE MAXIMUM RATINGS

### ● XC6108xxxA/B

Ta = 25°C

PARAMETER		SYMBOL	RATINGS	UNITS
Input Voltage		V <sub>IN</sub>	V <sub>SS</sub> -0.3 ~ 7.0	V
Output Current		I <sub>OUT</sub>	10	mA
Output Voltage	XC6108C (*1)	V <sub>OUT</sub>	V <sub>SS</sub> -0.3 ~ V <sub>IN</sub> +0.3	V
	XC6108N (*2)		V <sub>SS</sub> -0.3 ~ 7.0	
Sense Pin Voltage		V <sub>SEN</sub>	V <sub>SS</sub> -0.3 ~ 7.0	V
Delay Pin Voltage		V <sub>CD</sub>	V <sub>SS</sub> -0.3 ~ V <sub>IN</sub> +0.3	V
Delay Pin Current		I <sub>CD</sub>	5.0	mA
Power Dissipation	USP-4	P <sub>d</sub>	120	mW
	SOT-25		250	
Operating Temperature Range		T <sub>a</sub>	-40 ~ +85	°C
Storage Temperature Range		T <sub>stg</sub>	-55 ~ +125	°C

### ● XC6108xxxC/D

Ta = 25°C

PARAMETER		SYMBOL	RATINGS	UNITS
Input Voltage		V <sub>IN</sub>	V <sub>SS</sub> -0.3 ~ 7.0	V
Output Current		I <sub>OUT</sub>	10	mA
Output Voltage	XC6108C (*1)	V <sub>OUT</sub>	V <sub>SS</sub> -0.3 ~ V <sub>IN</sub> +0.3	V
	XC6108N (*2)		V <sub>SS</sub> -0.3 ~ 7.0	
Sense Pin Voltage		V <sub>SEN</sub>	V <sub>SS</sub> -0.3 ~ 7.0	V
Power Dissipation	USP-4	P <sub>d</sub>	120	mW
	SOT-25		250	
Operating Temperature Range		T <sub>a</sub>	-40 ~ +85	°C
Storage Temperature Range		T <sub>stg</sub>	-55 ~ +125	°C

NOTE:

\*1: CMOS output

\*2: N-ch open drain output

## ■ ELECTRICAL CHARACTERISTICS

● XC6108xxxA

Ta=25°C

PARAMETER	SYMBOL	CONDITIONS	MIN.	TYP.	MAX.	UNITS	CIRCUITS	
Operating Voltage	V <sub>IN</sub>	V <sub>DF(T)</sub> = 0.8 ~ 5.0V (*1)	1.0	-	6.0	V	-	
Detect Voltage	V <sub>DF</sub>	V <sub>IN</sub> = 1.0 ~ 6.0V	E-1			V	1	
Hysteresis Range1	V <sub>HYS1</sub>	V <sub>IN</sub> = 1.0 ~ 6.0V	E-2			V	1	
Detect Voltage Line Regulation	$\frac{\Delta V_{DF}}{\Delta V_{IN} \cdot V_{DF}}$	V <sub>IN</sub> = 1.0 ~ 6.0V	-	±0.1	-	%/V	1	
Supply Current 1 (*2)	ISS1	V <sub>SEN</sub> = V <sub>DF</sub> x 0.9	V <sub>IN</sub> = 1.0V	-	0.6	1.5	μA	2
			V <sub>IN</sub> = 6.0V	-	0.7	1.6		
Supply Current 2 (*2)	ISS2	V <sub>SEN</sub> = V <sub>DF</sub> x 1.1	V <sub>IN</sub> = 1.0V	-	0.8	1.7	μA	2
			V <sub>IN</sub> = 6.0V	-	0.9	1.8		
Output Current (*3)	I <sub>OUT</sub>	V <sub>SEN</sub> = 0V V <sub>DS</sub> = 0.5V (N-ch)	V <sub>IN</sub> = 1.0V	0.08	0.20	-	mA	3
			V <sub>IN</sub> = 6.0V	1.20	2.00	-		
		V <sub>SEN</sub> = 6.0V V <sub>DS</sub> = 0.5V (P-ch)	V <sub>IN</sub> = 1.0V	-	-0.30	-0.08	mA	4
			V <sub>IN</sub> = 6.0V	-	-2.00	-0.70		
Temperature Characteristics	$\frac{\Delta V_{DF}}{\Delta T_a \cdot V_{DF}}$	-40 °C ≤ T <sub>a</sub> ≤ 85°C	-	±100	-	ppm/°C	1	
Sense Resistance (*4)	R <sub>SEN</sub>	V <sub>SEN</sub> = 5.0V, V <sub>IN</sub> = 0V	E-4			MΩ	5	
Delay Resistance (*5)	R <sub>delay</sub>	V <sub>SEN</sub> = 6.0V, V <sub>IN</sub> = 5.0V, C <sub>d</sub> = 0V	1.6	2.0	2.4	MΩ	6	
Delay pin Sink Current	I <sub>CD</sub>	V <sub>DS</sub> = 0.5V, V <sub>IN</sub> = 1.0V	-	200	-	μA	6	
Delay Capacitance Pin Threshold Voltage	V <sub>TCD</sub>	V <sub>SEN</sub> = 6.0V, V <sub>IN</sub> = 1.0V	0.4	0.5	0.6	V	7	
		V <sub>SEN</sub> = 6.0V, V <sub>IN</sub> = 6.0V	2.9	3.0	3.1			
Unspecified Operating Voltage (*6)	V <sub>UNS</sub>	V <sub>IN</sub> = V <sub>SEN</sub> = 0V ~ 0.7V	-	0.3	0.4	V	8	
Detect Delay Time (*7)	T <sub>DF0</sub>	V <sub>IN</sub> = 6.0V, V <sub>SEN</sub> = 6.0V→0.0V C <sub>d</sub> : Open		30	230	μs	9	
Release Delay Time (*8)	T <sub>DR0</sub>	V <sub>IN</sub> = 6.0V, V <sub>SEN</sub> = 0.0V→6.0V C <sub>d</sub> : Open		30	200	μs	9	

NOTE:

\*1: V<sub>DF(T)</sub>: Setting detect voltage

\*2: Current flows the sense resistor is not included.

\*3: This numerical value is applied only to the XC6108C series (CMOS output).

\*4: Calculated from the voltage value and the current value of the V<sub>SEN</sub>.

\*5: Calculated from the voltage value of the V<sub>IN</sub> and the current value of the C<sub>d</sub>.

\*6: The maximum voltage of the V<sub>OUT</sub> in the range of the V<sub>IN</sub> 0V to 0.7V when the V<sub>IN</sub> and the V<sub>SEN</sub> are short-circuited

This numerical value is applied only to the XC6108C series (CMOS output).

\*7: Time which ranges from the state of V<sub>SEN</sub>=V<sub>DF</sub> to the V<sub>OUT</sub> reaching 0.6V when the V<sub>SEN</sub> falls without connecting to the C<sub>d</sub> pin.

\*8: Time which ranges from the state of V<sub>IN</sub>= V<sub>DF</sub> +V<sub>HYS</sub> to the V<sub>OUT</sub> reaching 5.4V when the V<sub>SEN</sub> rises without connecting to the C<sub>d</sub> pin.

**ELECTRICAL CHARACTERISTICS (Continued)**

● XC6108xxxB

Ta=25°C

PARAMETER	SYMBOL	CONDITIONS	MIN.	TYP.	MAX.	UNITS	CIRCUITS	
Operating Voltage	V <sub>IN</sub>	V <sub>DF(T)</sub> = 0.8 ~ 5.0V (*1)	1.0	-	6.0	V	-	
Detect Voltage	V <sub>DF</sub>	V <sub>IN</sub> = 1.0 ~ 6.0V	E-1			V	1	
Hysteresis Range1	V <sub>HYS1</sub>	V <sub>IN</sub> = 1.0 ~ 6.0V	E-3			V	1	
Detect Voltage Line Regulation	$\frac{\Delta V_{DF}}{\Delta V_{IN} \cdot V_{DF}}$	V <sub>IN</sub> = 1.0 ~ 6.0V	-	±0.1	-	%/V	1	
Supply Current 1 (*2)	ISS1	V <sub>SEN</sub> = V <sub>DF</sub> x 0.9	V <sub>IN</sub> = 1.0V	-	0.6	1.5	μA	2
			V <sub>IN</sub> = 6.0V	-	0.7	1.6		
Supply Current 2 (*2)	ISS2	V <sub>SEN</sub> = V <sub>DF</sub> x 1.1	V <sub>IN</sub> = 1.0V	-	0.8	1.7	μA	2
			V <sub>IN</sub> = 6.0V	-	0.9	1.8		
Output Current (*3)	I <sub>OUT</sub>	V <sub>SEN</sub> = 0V V <sub>DS</sub> = 0.5V (N-ch)	V <sub>IN</sub> = 1.0V	0.08	0.20	-	mA	3
			V <sub>IN</sub> = 6.0V	1.20	2.00	-		
		V <sub>SEN</sub> = 6.0V V <sub>DS</sub> = 0.5V (P-ch)	V <sub>IN</sub> = 1.0V	-	-0.30	-0.08	mA	4
			V <sub>IN</sub> = 6.0V	-	-2.00	-0.70		
Temperature Characteristics	$\frac{\Delta V_{DF}}{\Delta T_a \cdot V_{DF}}$	-40 °C ≤ Ta ≤ 85°C	-	±100	-	ppm/°C	1	
Sense Resistance (*4)	R <sub>SEN</sub>	V <sub>SEN</sub> = 5.0V, V <sub>IN</sub> = 0V	E-4			MΩ	5	
Delay Resistance (*5)	R <sub>delay</sub>	V <sub>SEN</sub> = 6.0V, V <sub>IN</sub> = 5.0V, Cd = 0V	1.6	2.0	2.4	MΩ	6	
Delay pin Sink Current	I <sub>CD</sub>	V <sub>DS</sub> = 0.5V, V <sub>IN</sub> = 1.0V	-	200	-	μA	6	
Delay Capacitance Pin Threshold Voltage	V <sub>TCD</sub>	V <sub>SEN</sub> = 6.0V, V <sub>IN</sub> = 1.0V	0.4	0.5	0.6	V	7	
		V <sub>SEN</sub> = 6.0V, V <sub>IN</sub> = 6.0V	2.9	3.0	3.1			
Unspecified Operating Voltage (*6)	V <sub>UNS</sub>	V <sub>IN</sub> = V <sub>SEN</sub> = 0V ~ 0.7V	-	0.3	0.4	V	8	
Detect Delay Time (*7)	T <sub>DF0</sub>	V <sub>IN</sub> = 6.0V, V <sub>SEN</sub> = 6.0V→0.0V Cd: Open		30	230	μs	9	
Release Delay Time (*8)	T <sub>DR0</sub>	V <sub>IN</sub> = 6.0V, V <sub>SEN</sub> = 0.0V→6.0V Cd: Open		30	200	μs	9	

NOTE:

 \*1: V<sub>DF(T)</sub>: Setting detect voltage

\*2: Current flows the sense resistor is not included.

\*3: This numerical value is applied only to the XC6108C series (CMOS output).

 \*4: Calculated from the voltage value and the current value of the V<sub>SEN</sub>.

 \*5: Calculated from the voltage value of the V<sub>IN</sub> and the current value of the Cd.

 \*6: The maximum voltage of the V<sub>OUT</sub> in the range of the V<sub>IN</sub> 0V to 0.7V when the V<sub>IN</sub> and the V<sub>SEN</sub> are short-circuited  
 This numerical value is applied only to the XC6108C series (CMOS output).

 \*7: Time which ranges from the state of V<sub>SEN</sub>=V<sub>DF</sub> to the V<sub>OUT</sub> reaching 0.6V when the V<sub>SEN</sub> falls without connecting to the Cd pin.

 \*8: Time which ranges from the state of V<sub>IN</sub>= V<sub>DF</sub> +V<sub>HYS</sub> to the V<sub>OUT</sub> reaching 5.4V when the V<sub>SEN</sub> rises without connecting to the Cd pin.

## ■ ELECTRICAL CHARACTERISTICS (Continued)

● XC6108xxxC

Ta=25°C

PARAMETER	SYMBOL	CONDITIONS	MIN.	TYP.	MAX.	UNITS	CIRCUITS	
Operating Voltage	V <sub>IN</sub>	V <sub>DF(T)</sub> = 0.8 ~ 5.0V (*1)	1.0	-	6.0	V	-	
Detect Voltage	V <sub>DF</sub>	V <sub>IN</sub> = 1.0 ~ 6.0V	E-1			V	1	
Hysteresis Range1	V <sub>HYS1</sub>	V <sub>IN</sub> = 1.0 ~ 6.0V	E-2			V	1	
Detect Voltage Line Regulation	$\frac{\Delta V_{DF}}{\Delta V_{IN} \cdot V_{DF}}$	V <sub>IN</sub> = 1.0 ~ 6.0V	-	±0.1	-	%/V	1	
Supply Current 1 (*2)	ISS1	V <sub>SEN</sub> =	V <sub>IN</sub> = 1.0V	-	0.6	1.5	μA	2
		V <sub>DF</sub> x 0.9	V <sub>IN</sub> = 6.0V	-	0.7	1.6		
Supply Current 2 (*2)	ISS2	V <sub>SEN</sub> =	V <sub>IN</sub> = 1.0V	-	0.8	1.7	μA	2
		V <sub>DF</sub> x 1.1	V <sub>IN</sub> = 6.0V	-	0.9	1.8		
Output Current (*3)	I <sub>OUT</sub>	V <sub>SEN</sub> = 0V	V <sub>IN</sub> = 1.0V	0.08	0.20	-	mA	3
		V <sub>DS</sub> = 0.5V (N-ch)	V <sub>IN</sub> = 6.0V	1.20	2.00	-		
		V <sub>SEN</sub> = 6.0V	V <sub>IN</sub> = 1.0V	-	-0.30	-0.08	mA	4
		V <sub>DS</sub> = 0.5V (P-ch)	V <sub>IN</sub> = 6.0V	-	-2.00	-0.70		
Temperature Characteristics	$\frac{\Delta V_{DF}}{\Delta T_a \cdot V_{DF}}$	-40 °C ≤ T <sub>a</sub> ≤ 85°C	-	±100	-	ppm/°C	1	
Sense Resistance (*4)	R <sub>SEN</sub>	V <sub>SEN</sub> = 5.0V, V <sub>IN</sub> = 0V	E-4			MΩ	5	
Unspecified Operating Voltage (*5)	V <sub>UNS</sub>	V <sub>IN</sub> = V <sub>SEN</sub> = 0V ~ 0.7V	-	0.3	0.4	V	7	
Detect Delay Time (*6)	T <sub>DF0</sub>	V <sub>IN</sub> = 6.0V, V <sub>SEN</sub> = 6.0V→0.0V		30	230	μs	9	
Release Delay Time (*7)	T <sub>DR0</sub>	V <sub>IN</sub> = 6.0V, V <sub>SEN</sub> = 0.0V→6.0V		30	200	μs	9	

NOTE:

\*1: V<sub>DF(T)</sub>: Setting detect voltage

\*2: Current flows the sense resistor is not included.

\*3: This numerical value is applied only to the XC6108C series (CMOS output).

\*4: Calculated from the voltage value and the current value of the V<sub>SEN</sub>.

\*5: The maximum voltage of the V<sub>OUT</sub> in the range of the V<sub>IN</sub> 0V to 0.7V when the V<sub>IN</sub> and the V<sub>SEN</sub> are short-circuited  
This numerical value is applied only to the XC6108C series (CMOS output).

\*6: Time which ranges from the state of V<sub>SEN</sub>=V<sub>DF</sub> to the V<sub>OUT</sub> reaching 0.6V when the V<sub>SEN</sub> falls.

\*7: Time which ranges from the state of V<sub>IN</sub>= V<sub>DF</sub> +V<sub>HYS</sub> to the V<sub>OUT</sub> reaching 5.4V when the V<sub>SEN</sub> rises.



**■ ELECTRICAL CHARACTERISTICS (Continued)**

● XC6108xxxD

Ta=25°C

PARAMETER	SYMBOL	CONDITIONS	MIN.	TYP.	MAX.	UNITS	CIRCUITS	
Operating Voltage	V <sub>IN</sub>	V <sub>DF(T)</sub> = 0.8 ~ 5.0V (*1)	1.0	-	6.0	V	-	
Detect Voltage	V <sub>DF</sub>	V <sub>IN</sub> = 1.0 ~ 6.0V	E-1			V	1	
Hysteresis Range1	V <sub>HYS1</sub>	V <sub>IN</sub> = 1.0 ~ 6.0V	E-3			V	1	
Detect Voltage Line Regulation	$\frac{\Delta V_{DF}}{\Delta V_{IN} \cdot V_{DF}}$	V <sub>IN</sub> = 1.0 ~ 6.0V	-	±0.1	-	%/V	1	
Supply Current 1 (*2)	I <sub>SS1</sub>	V <sub>SEN</sub> = V <sub>DF</sub> x 0.9	V <sub>IN</sub> = 1.0V - V <sub>IN</sub> = 6.0V	0.6 0.7	1.5 1.6	μA	2	
Supply Current 2 (*2)	I <sub>SS2</sub>	V <sub>SEN</sub> = V <sub>DF</sub> x 1.1	V <sub>IN</sub> = 1.0V - V <sub>IN</sub> = 6.0V	0.8 0.9	1.7 1.8	μA	2	
Output Current (*3)	I <sub>OUT</sub>	V <sub>SEN</sub> = 0V V <sub>DS</sub> = 0.5V (N-ch)	V <sub>IN</sub> = 1.0V - V <sub>IN</sub> = 6.0V	0.08 1.20	0.20 2.00	- -	mA	3
		V <sub>SEN</sub> = 6.0V V <sub>DS</sub> = 0.5V (P-ch)	V <sub>IN</sub> = 1.0V - V <sub>IN</sub> = 6.0V	- -	-0.30 -2.00	-0.08 -0.70	mA	4
Temperature Characteristics	$\frac{\Delta V_{DF}}{\Delta T_a \cdot V_{DF}}$	-40 °C ≤ T <sub>a</sub> ≤ 85 °C	-	±100	-	ppm/°C	1	
Sense Resistance (*4)	R <sub>SEN</sub>	V <sub>SEN</sub> = 5.0V, V <sub>IN</sub> = 0V	E-4			MΩ	5	
Unspecified Operating Voltage (*5)	V <sub>UNS</sub>	V <sub>IN</sub> = V <sub>SEN</sub> = 0V ~ 0.7V	-	0.3	0.4	V	7	
Detect Delay Time (*6)	T <sub>DF0</sub>	V <sub>IN</sub> = 6.0V, V <sub>SEN</sub> = 6.0V→0.0V		30	230	μs	9	
Release Delay Time (*7)	T <sub>DR0</sub>	V <sub>IN</sub> = 6.0V, V <sub>SEN</sub> = 0.0V→6.0V		30	200	μs	9	

**NOTE:**

 \*1: V<sub>DF(T)</sub>: Setting detect voltage

\*2: Current flows the sense resistor is not included.

\*3: This numerical value is applied only to the XC6108C series (CMOS output).

 \*4: Calculated from the voltage value and the current value of the V<sub>SEN</sub>.

 \*5: The maximum voltage of the V<sub>OUT</sub> in the range of the V<sub>IN</sub> 0V to 0.7V when the V<sub>IN</sub> and the V<sub>SEN</sub> are short-circuited  
 This numerical value is applied only to the XC6108C series (CMOS output).

 \*6: Time which ranges from the state of V<sub>SEN</sub>=V<sub>DF</sub> to the V<sub>OUT</sub> reaching 0.6V when the V<sub>SEN</sub> falls.

 \*7: Time which ranges from the state of V<sub>IN</sub>= V<sub>DF</sub> +V<sub>HYS</sub> to the V<sub>OUT</sub> reaching 5.4V when the V<sub>SEN</sub> rises.

## ■ VOLTAGE CHART

SYMBOL	E-1		E-2		E-3		E-4	
SETTING OUTPUT VOLTAGE	DETECT VOLTAGE (*1) (V)		HYSTERESIS RANGE (V)		HYSTERESIS RANGE (V)		SENSE RESISTANCE (MΩ)	
VDF(T) (V)	VDF		VHYS		VHYS		RSEN	
	MIN.	MAX.	MIN.	MAX.	MIN.	MAX.	MIN.	TYP.
0.8	0.770	0.830	0.015	0.066	0	0.008	10	20
0.9	0.870	0.930	0.017	0.074		0.009		
1.0	0.970	1.030	0.019	0.082		0.010		
1.1	1.070	1.230	0.021	0.090		0.011		
1.2	1.170	1.230	0.023	0.098		0.012		
1.3	1.270	1.330	0.025	0.106		0.013		
1.4	1.370	1.430	0.027	0.114		0.014		
1.5	1.470	1.530	0.029	0.122		0.015		
1.6	1.568	1.632	0.031	0.131		0.016		
1.7	1.666	1.734	0.033	0.085		0.017		
1.8	1.764	1.836	0.035	0.147		0.018		
1.9	1.862	1.938	0.037	0.155		0.019		
2.0	1.960	2.040	0.039	0.163		0.020		
2.1	2.058	2.142	0.041	0.171		0.021		
2.2	2.156	2.244	0.043	0.180		0.022		
2.3	2.254	2.346	0.045	0.188		0.023		
2.4	2.352	2.448	0.047	0.196		0.024		
2.5	2.450	2.550	0.049	0.204	0.026			
2.6	2.548	2.652	0.051	0.212	0.027			
2.7	2.646	2.754	0.053	0.220	0.028			
2.8	2.744	2.856	0.055	0.228	0.029			
2.9	2.842	2.958	0.057	0.237	0.030			
3.0	2.940	3.060	0.059	0.245	0.031			
3.1	3.038	3.162	0.061	0.253	0.032			
3.2	3.136	3.264	0.063	0.261	0.033			
3.3	3.234	3.366	0.065	0.269	0.034			
3.4	3.332	3.468	0.067	0.277	0.035			
3.5	3.430	3.570	0.069	0.286	0.036			
3.6	3.528	3.672	0.071	0.294	0.037			
3.7	3.626	3.774	0.073	0.302	0.038			
3.8	3.724	3.876	0.074	0.310	0.039			
3.9	3.822	3.978	0.076	0.318	0.040			
4.0	3.920	4.080	0.078	0.326	0.041			
4.1	4.018	4.182	0.080	0.335	0.042			
4.2	4.116	4.284	0.082	0.343	0.043			
4.3	4.214	4.386	0.084	0.351	0.044			
4.4	4.312	4.488	0.086	0.359	0.045			
4.5	4.410	4.590	0.088	0.367	0.046			
4.6	4.508	4.692	0.090	0.375	0.047			
4.7	4.606	4.794	0.092	0.384	0.048			
4.8	4.704	4.896	0.094	0.392	0.049			
4.9	4.802	4.998	0.096	0.400	0.050			
5.0	4.900	5.100	0.098	0.408	0.051			

NOTE:

\*1: When  $VDF(T) \leq 1.4V$ , the detection accuracy is  $\pm 30mV$ .

When  $VDF(T) \geq 1.5V$ , the detection accuracy is  $\pm 2\%$ .

## ■ TEST CIRCUITS

Circuit 1

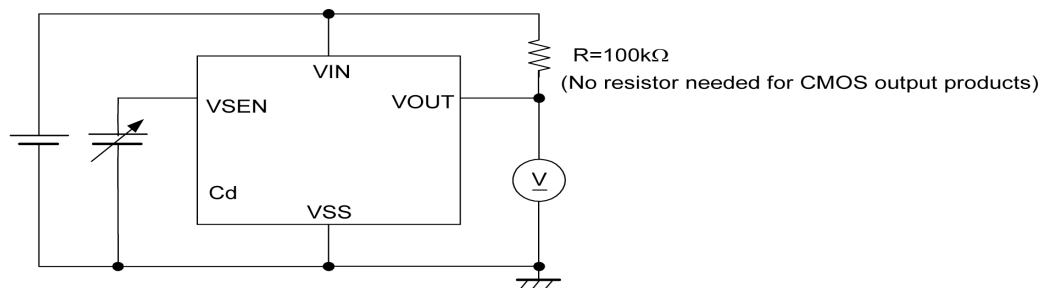

Circuit 2

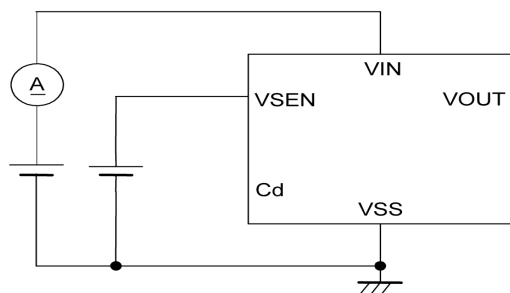

Circuit 3

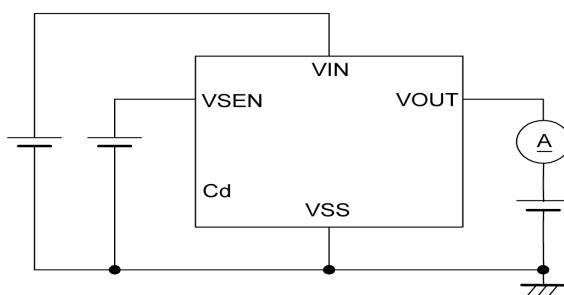

Circuit 4

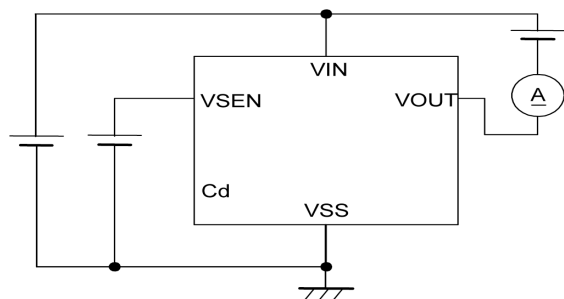

Circuit 5

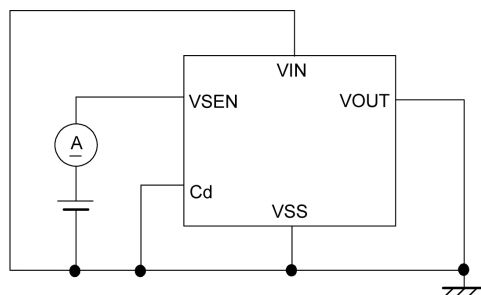

## ■ TEST CIRCUITS (Continued)

Circuit 6

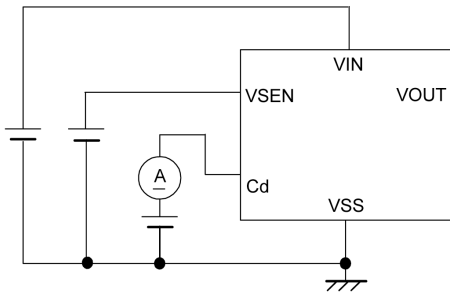

Circuit 7

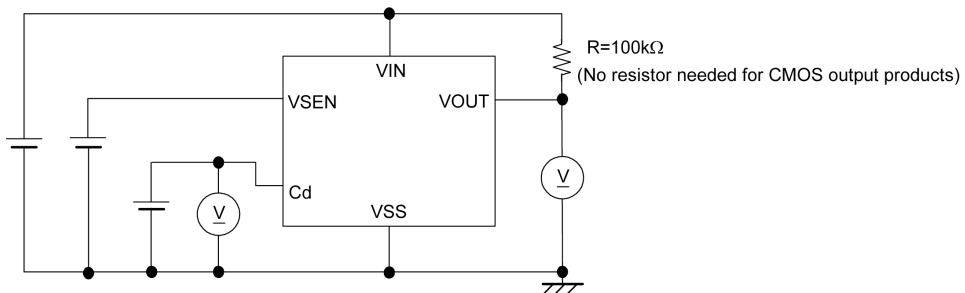

Circuit 8

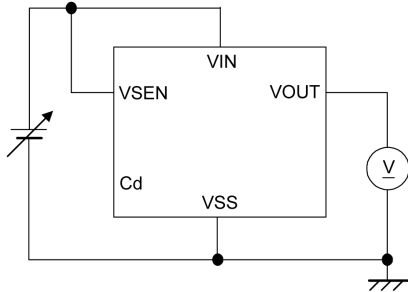

Circuit 9

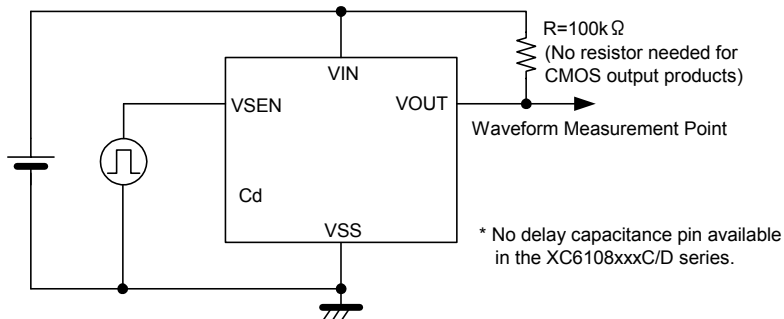

## OPERATIONAL EXPLANATION

A typical circuit example is shown in Figure 1, and the timing chart of Figure 1 is shown in Figure 2 on the next page.

- ① As an early state, the sense pin is applied sufficiently high voltage (6.0V MAX.) and the delay capacitance (Cd) is charged to the power supply input voltage, (VIN: 1.0V MIN., 6.0V MAX.). While the sense pin voltage (VSEN) starts dropping to reach the detect voltage (VDF) (VSEN>VDF), the output voltage (VOUT) keeps the "High" level (=VIN).  
\* If a pull-up resistor of the XC6108N series (N-ch open drain) is connected to added power supply different from the input voltage pin, the "High" level will be a voltage value where the pull-up resistor is connected.
- ② When the sense pin voltage keeps dropping and becomes equal to the detect voltage, an N-ch transistor for the delay capacitance discharge is turned ON, and starts to discharge the delay capacitance. For the internal circuit, which uses the delay capacitance pin as power input, the reference voltage operates as a comparator of VIN, and the output voltage changes into the "Low" level (=VSS). The detect delay time [TDF] is defined as time which ranges from VSEN=VDF to the VOUT of "Low" level (especially, when the Cd pin is not connected: TDF0).
- ③ While the sense pin voltage keeps below the detect voltage, the delay capacitance is discharged to the ground voltage (=VSS) level. Then, the output voltage maintains the "Low" level while the sense pin voltage increases again to reach the release voltage (VSEN< VDF +VHYS).
- ④ When the sense pin voltage continues to increase up to the release voltage level (VDF+VHYS), the N-ch transistor for the delay capacitance discharge will be turned OFF, and the delay capacitance will start discharging via a delay resistor (Rdelay). The internal circuit, which uses the delay capacitance pin as power input, will operate as a hysteresis comparator (Rise Logic Threshold: VTLH=VTCD, Fall Logic Threshold: VTHL=VSS) while the sense pin voltage keeps higher than the detect voltage (VSEN > VDF).
- ⑤ While the delay capacitance pin voltage (VCD) rises to reach the delay capacitance pin threshold voltage (VTCD) with the sense pin voltage equal to the release voltage or higher, the sense pin will be charged by the time constant of the RC series circuit. Assuming the time to the release delay time (TDR), it can be given by the formula (1).

$$TDR = -R_{delay} \times Cd \times \ln(1 - VTCD / VIN) \dots(1)$$

\* ln = a natural logarithm

The release delay time can also be briefly calculated with the formula (2) because the delay resistance is 2.0MΩ (TYP.) and the delay capacitance pin voltage is VIN / 2 (TYP.)

$$TDR = 2.0e6 \times Cd \times 0.69 \dots(2)$$

As an example, presuming that the delay capacitance is 0.68 μF, TDR is :

$$2.0e6 \times 0.68e-6 \times 0.69 = 938 \text{ (ms)}$$

\* Note that the release delay time may remarkably be short when the delay capacitance is not discharged to the ground (=VSS) level because time described in ③ is short.

- ⑥ When the delay capacitance pin voltage reaches to the delay capacitance pin threshold voltage (VCD=VTCD), output of an internal circuit, which uses the delay capacitance pin as power input will be inverted. As a result, the output voltage changes into the "High" (=VIN) level. TDR0 is defined as time which ranges from VSEN=VDF+VHYS to the VOUT of "High" level without connecting to the Cd.
- ⑦ While the sense voltage is higher than the detect voltage (VSEN > VDF), the delay capacitance pin is charged until the delay capacitance pin voltage becomes the input voltage level. Therefore, the output voltage maintains the "High"(=VIN) level.

### Release Delay Time Chart

Delay Capacitance [Cd] (μF)	Release Delay Time [TDR] (TYP.) (ms)	Release Delay Time [TDR] (MIN. ~ MAX.) (ms)
0.010	13.8	11.0 ~ 16.6
0.022	30.4	24.3 ~ 36.4
0.047	64.9	51.9 ~ 77.8
0.100	138	110 ~ 166
0.220	304	243 ~ 364
0.470	649	519 ~ 778
1.000	1380	1100 ~ 1660

## OPERATIONAL EXPLANATION (Continued)

Figure 1: Typical application circuit example

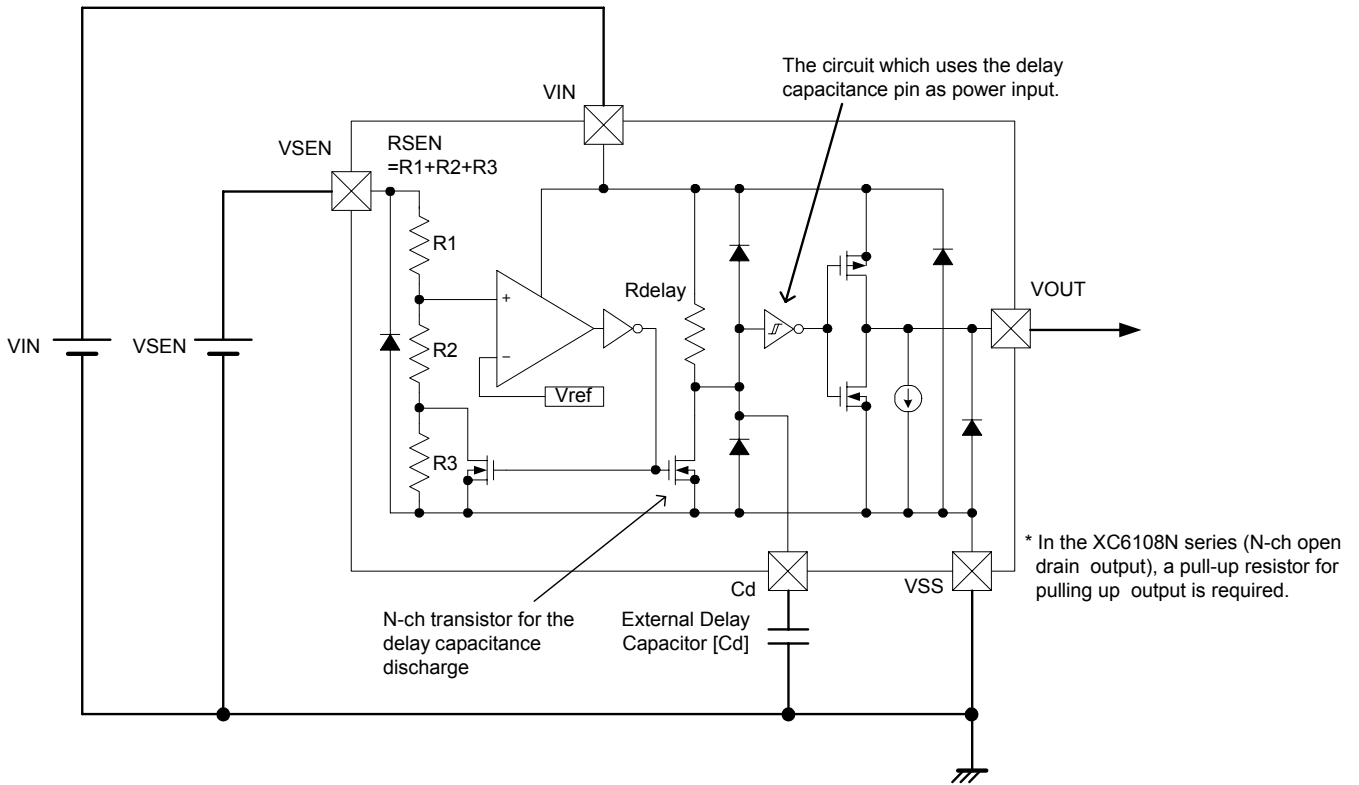
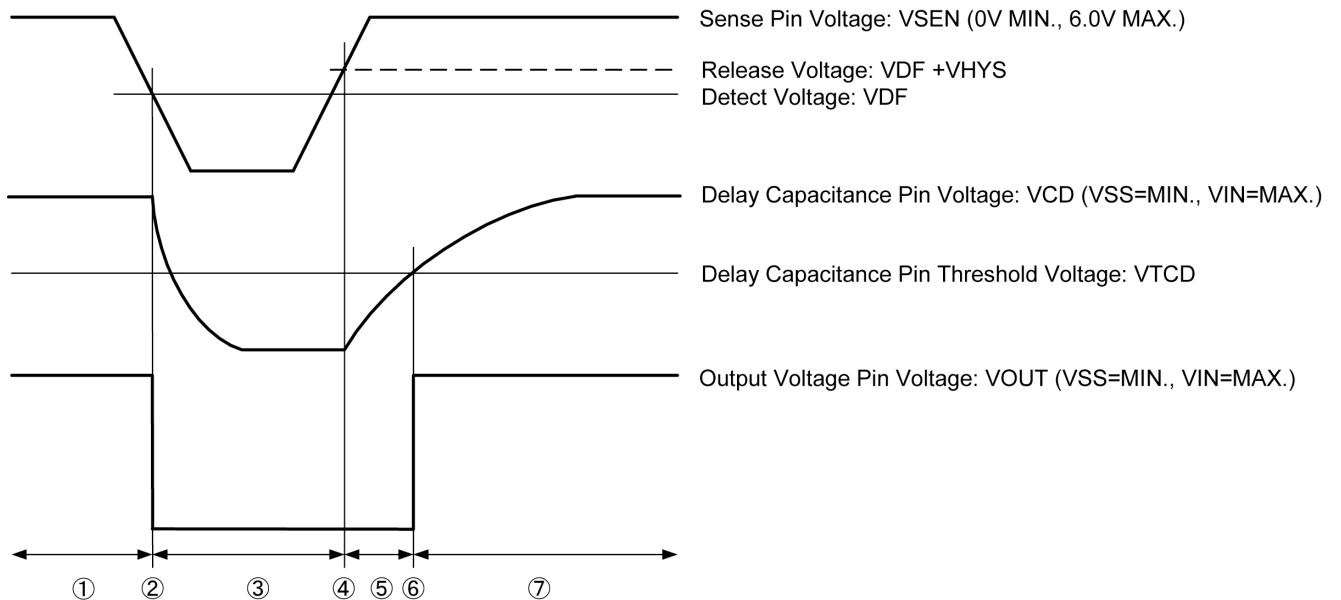

Figure 2: The timing chart of Figure 1



## ■ NOTES ON USE

1. Use this IC within the stated maximum ratings. Operation beyond these limits may cause degrading or permanent damage to the device.
2. The power supply input pin voltage drops by the resistance between power supply and the  $V_{IN}$  pin, and by through current at operation of the IC. At this time, the operation may be wrong if the power supply input pin voltage falls below the minimum operating voltage range. In CMOS output, for output current, drops in the power supply input pin voltage similarly occur. Moreover, in CMOS output, when the  $V_{IN}$  pin and the sense pin are short-circuited and used, oscillation of the circuit may occur if the drops in voltage, which caused by through current at operation of the IC, exceed the hysteresis voltage. Note it especially when you use the IC with the  $V_{IN}$  pin connected to a resistor.
3. When the setting voltage is less than 1.0V, be sure to separate the  $V_{IN}$  pin and the sense pin, and to apply the voltage over 1.0V to the  $V_{IN}$  pin.
4. Note that a rapid and high fluctuation of the power supply input pin voltage may cause a wrong operation.
5. When there is a possibility of which the power supply input pin voltage falls rapidly (e.g.: 6.0V to 0V) at release operation with the delay capacitance pin ( $C_d$ ) connected to a capacitor, use a schottky barrier diode connected between the  $V_{IN}$  pin and the  $C_d$  pin as the Figure 3 shown below.
6. In N-ch open drain output, a pull-up resistor connected to the output voltage pin should be 100k-200k $\Omega$ .

Figure 3: Circuit example with the delay capacitance pin ( $C_d$ ) connected to a schottky barrier diode

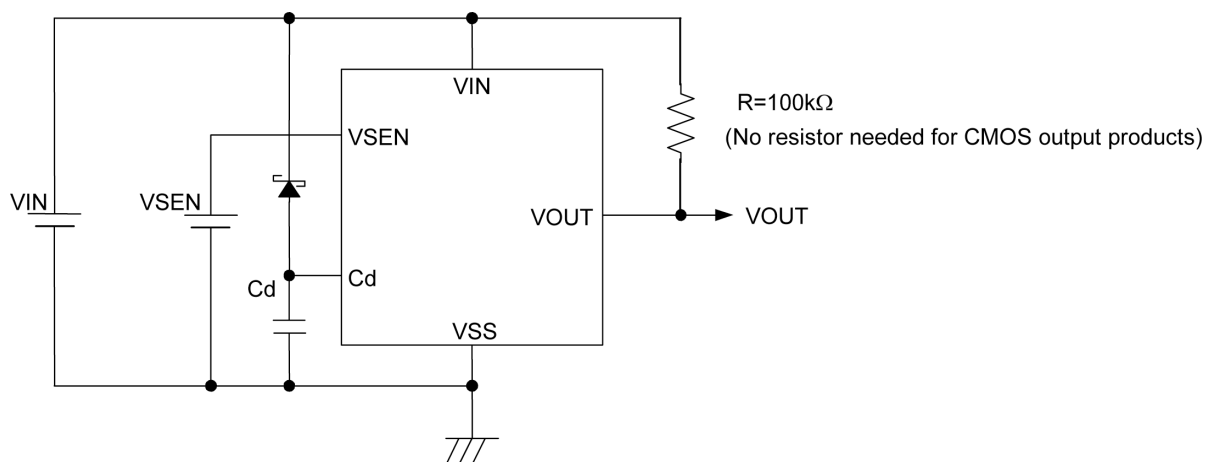

## ■ TYPICAL PERFORMANCE CHARACTERISTICS

(1) Supply Current vs. Sense Voltage

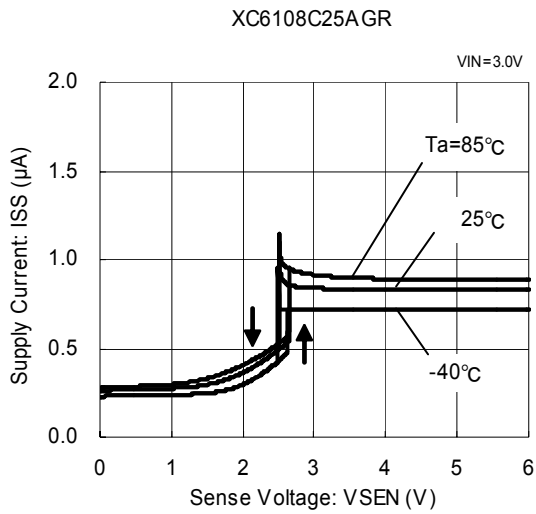

(2) Supply Current vs. Input Voltage

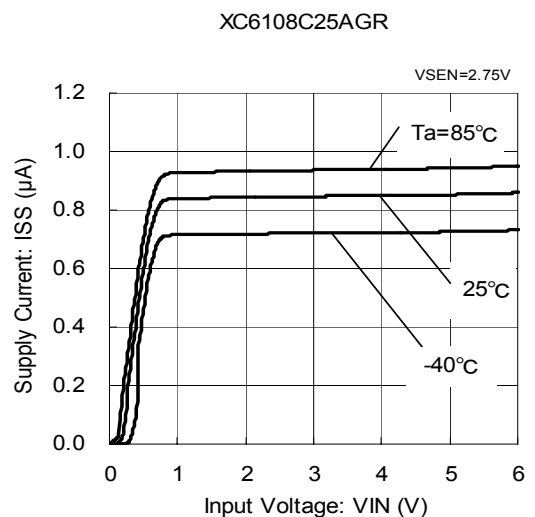
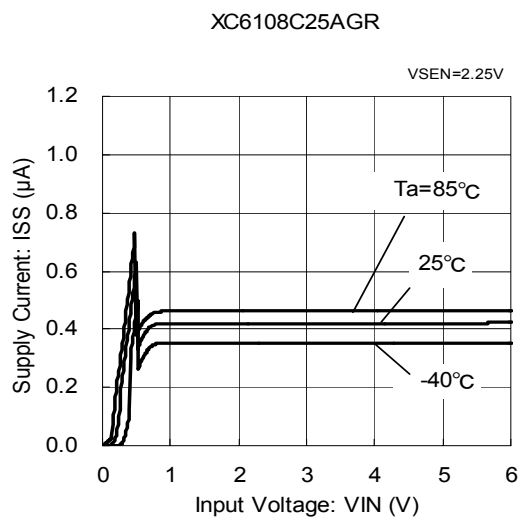

(3) Detect Voltage vs. Ambient Temperature

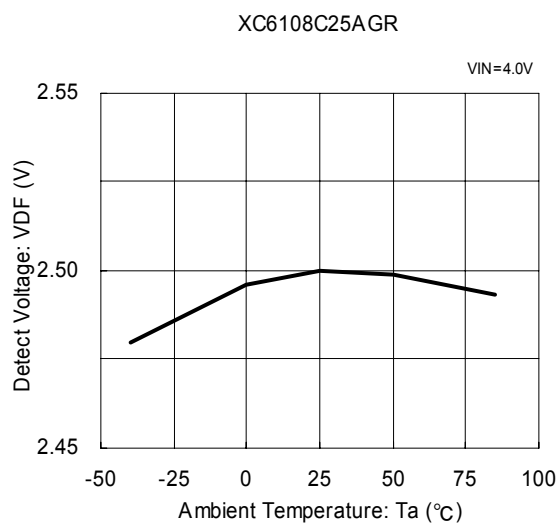

(4) Detect Voltage vs. Input Voltage

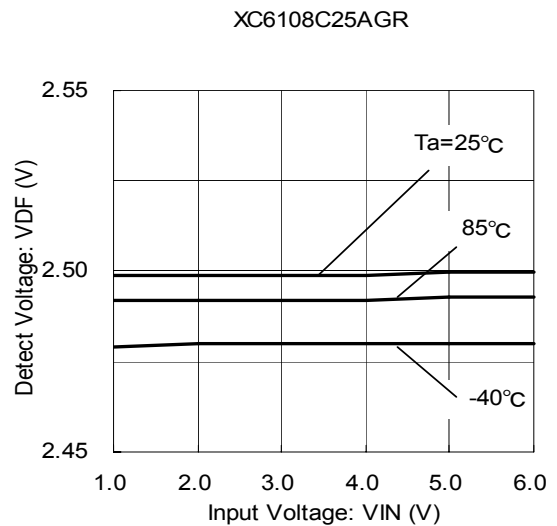



## ■ TYPICAL PERFORMANCE CHARACTERISTICS (Continued)

(5) Hysteresis Voltage vs. Ambient Temperature

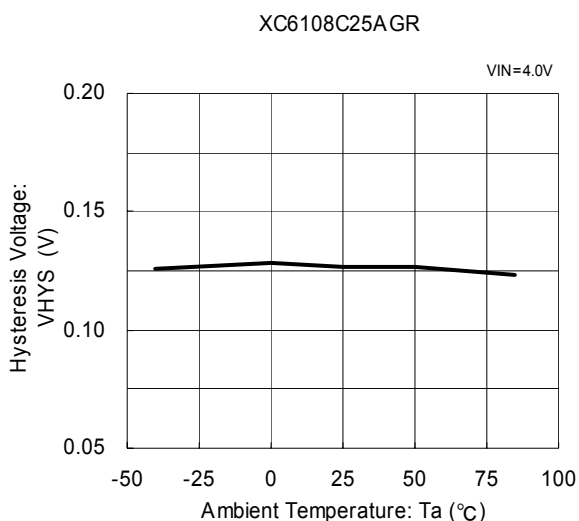

(6) CD Pin Sink Current vs. Input Voltage

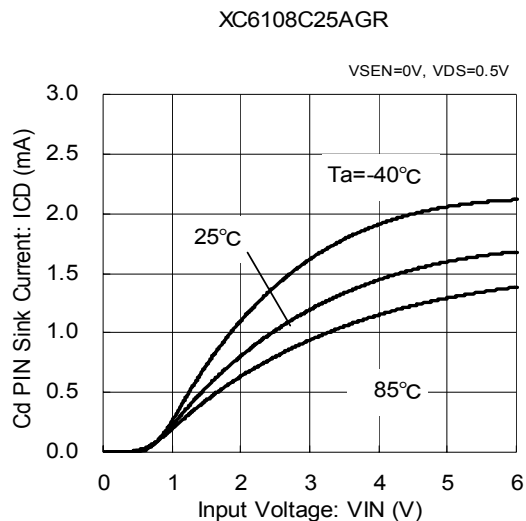

(7) Output Voltage vs. Sense Voltage

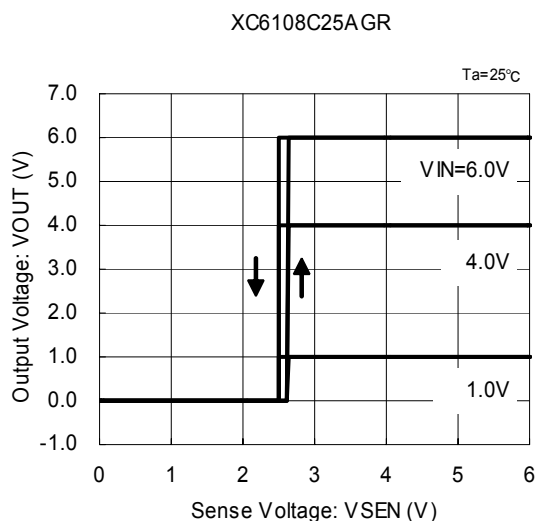

(8) Output Voltage vs. Input Voltage

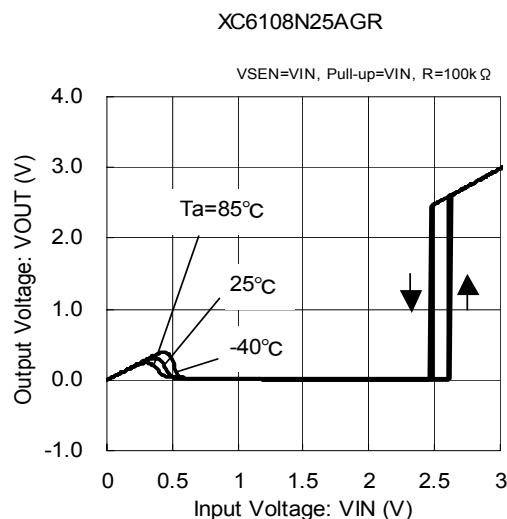

(9) Output Current vs. Input Voltage

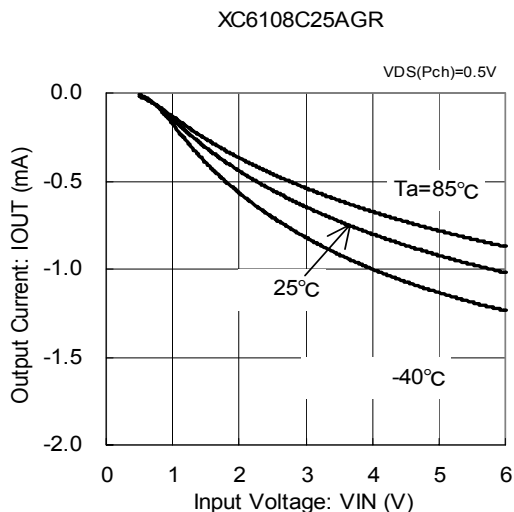
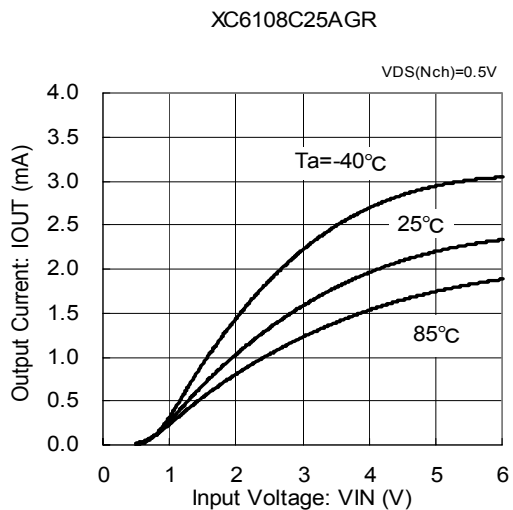

## ■ TYPICAL PERFORMANCE CHARACTERISTICS (Continued)

(10) Delay Resistance vs. Ambient Temperature

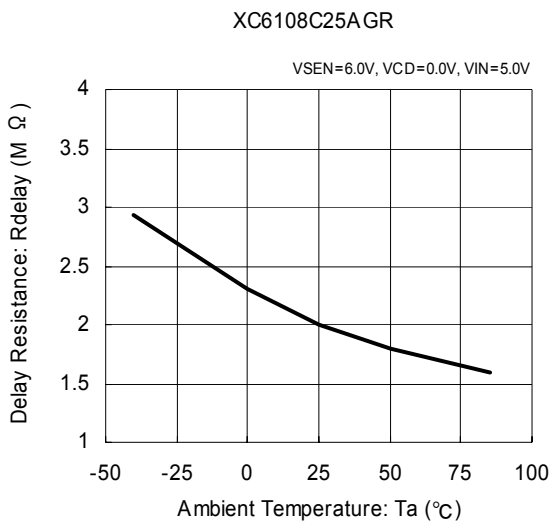

(11) Release Delay Time vs. Delay Capacitance

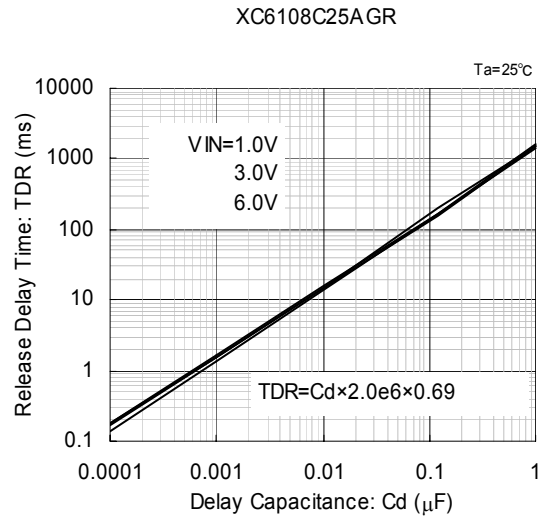

(12) Detect Delay Time vs. Delay Capacitance

